



MODEL 44-50
VIBRATORY
DRIVER/EXTRACTOR

OPERATING AND MAINTENANCE MANUAL

J&M MODEL 44-50

VIBRATORY PILE DRIVER/EXTRACTOR

WITH MODEL 580 POWER PACK

OM-44-50/580-1215



**J&M FOUNDATION
EQUIPMENT, LLC**

SPECIALIZING IN PILE DRIVING EQUIPMENT



MODEL 44-50
VIBRATORY
DRIVER/EXTRACTOR



**MODEL 44-50
VIBRATORY
DRIVER/EXTRACTOR**

J&M MODEL 44-50
VIBRATORY PILE DRIVER/EXTRACTOR
WITH MODEL 580 POWER UNIT
OM-44-50/580-0409

PREFACE

INFORMATION This manual was prepared to acquaint the owner, operator and serviceman with the operation and maintenance of the vibratory driver/extractor. We strongly suggest that this manual be carefully studied before operating or undertaking any maintenance work on the unit. It is not meant to be all inclusive as to content, and any questions and/or doubt should be directed to J&M before proceeding with any operation or maintenance.

This manual is organized into two major categories.

The first category is for OPERATING INSTRUCTIONS of the unit and includes a GENERAL DESCRIPTION section, which presents a basic explanation of the driver/extractor specifications. The MAINTENANCE AND ADJUSTMENT section should be referred to for all servicing of equipment. All machines and equipment require systematic, periodic inspection and maintenance, if they are to perform satisfactorily.

The second category is for parts ordering and it includes both a PARTS LIST and a pictorial drawing of the assembly. Refer to the ORDERING PARTS section of the PARTS LIST for more specific procedures regarding parts ordering. Adherence of the listed procedures will insure receipt of the required part(s) with the minimal amount of delay or error.

Manual release date: 4-28-2009

J&M reserves the right to update or revise this manual as required, check with J&M for current release date.



MODEL 44-50
VIBRATORY
DRIVER/EXTRACTOR



**MODEL 44-50
VIBRATORY
DRIVER/EXTRACTOR**

Warranty

American Piledriving Equipment, Inc. J&M Foundation Equipment LLC
STANDARD WARRANTY

American Piledriving Equipment, Inc./J&M Foundation Equipment LLC (APE/J&M) warrants new products sold by it to be free from defects in material or workmanship for a period of one year after the date of delivery to the first user and subject to the following conditions:

APE/J&M's obligation and liability under this WARRANTY is expressly limited to repairing or replacing at APE/J&M's option, any parts which appear to APE/J&M upon inspection to have been defective in material or

workmanship. Such parts shall be provided at no cost to the user, at the business establishment of APE/J&M or the authorized APE/J&M distributor of the product during regular working hours. This WARRANTY, shall not apply to component parts or accessories of products not manufactured by APE/J&M and which carry the warranty of the manufacturer thereof, or to normal maintenance (scraped and scived lube and fuel lines, worn cushion material in the drive base) or normal maintenance parts (such as fouled injectors, weakened check valve springs, damaged grease zirts caused by use over time).

Replacement or repair parts installed in the product covered by this WARRANTY are warranted only for the remainder of the warranty as if such parts were original components of said product. APE/J&M makes no other warranty, expressed or implied and makes no warranty of merchantability of fitness for any particular purpose.

APE's obligation under this WARRANTY shall not include any transportation charges, costs of installation, duty, taxes or any other charges whatsoever, or any liability for direct, indirect, incidental or consequential damage or delay. If requested by APE/J&M, products or parts for which a warranty claim is made are to be returned transportation prepaid to APE/J&M. Any improper use, including operation after discovery of defective or worn parts, operation beyond rated capacity, substitution of any parts whatsoever, or parts not approved by APE/J&M or any alteration or repair by others in such manner as in APE/J&M's judgment affects the product materially and adversely, shall void this warranty.

**ANY TYPE OF WELDING ON EQUIPMENT
WILL VOID THE WARRANTY**

Refusal: Vibros: If the pile does not move one foot in 30 seconds of vibro operation at full speed. Resort to a larger vibro. APE/J&M equipment may exceed the refusal driving criteria for short periods of time as may be needed to penetrate hard soil layers or obstacles. In such cases, a heat gun is used to monitor the temperature of the bearings and related components to prevent use of the machine beyond 210 degrees. Contact APE/J&M or your local APE/J&M distributor for special instructions when faced with refusal conditions.

Refusal: Diesels: Do not exceed 10 blows per inch or 120 blows per foot. In cases of setting of the pile it is permitted to increase the blow count to 250 blows per foot, but only for one foot of driving penetration. Pile inspectors should consult the APE factory for permission to exceed these limits. Failure to do so will void the warranty. This standard specification is accepted by the DFI (Deep Foundations Institute) and the PDCA (Pile Contractors Association) and by all manufacturers of pile driving equipment.



**MODEL 44-50
VIBRATORY
DRIVER/EXTRACTOR**

TABLE OF CONTENTS

| I. | <u>GENERAL DESCRIPTION</u> | <u>PAGE</u> |
|-------------|---|--------------------|
| | A. General | I- 1 |
| | B. Vibrator | I- 2 |
| | C. Hydraulic Clamp | I- 2 |
| | D. Power Unit | I- 2 |
| | E. Remote-Control Pendant | I- 3 |
| | F. Specifications | I- 3 |
| II. | <u>PREPARATION FOR OPERATING</u> | |
| | A. General | II- 1 |
| | B. Safety Precautions | II- 1 |
| | C. Rigging of Vibrator | II- 5 |
| | D. Connection of Hydraulic Clamp | II- 5 |
| | E. Connection of Hydraulic Hoses | II- 6 |
| | F. Bleeding Hydraulic Clamp Hoses | II- 8 |
| | G. Filling Vibrator Pressure Hose | II- 8 |
| III. | <u>OPERATING INSTRUCTIONS</u> | |
| | Control Panel with Remote Pendant | III- 1 |
| | A. Completion of Set-Up and Maintenance | III- 2 |
| | B. Control Panel | III- 2 |
| | C. Starting and Warming Up Engine | III- 3 |
| | D. Warming Hydraulic Fluid | III- 4 |
| | E. Operation of Control Pendant | III- 4 |
| | F. Changing Frequency | III- 6 |
| | G. Shutdown | III- 6 |
| IV. | <u>MAINTENANCE AND ADJUSTMENTS</u> | |
| | A. General | IV- 1 |
| | B. Daily | IV- 1 |
| | C. 100 Hours, 500 Hours and Other | IV- 2 |
| | D. Annually | IV- 2 |
| | E. Severe Conditions | IV- 3 |
| | F. Lubrication | IV- 3 |
| | G. Capacities | IV- 7 |
| | H. Draining and Filling Hydraulic Fluid Reservoir | IV- 8 |
| | I. Changing Hydraulic Return Filter Element | IV- 8 |
| | J. Bolt Torque Information | IV- 9 |



**MODEL 44-50
VIBRATORY
DRIVER/EXTRACTOR**

TABLE OF CONTENTS

| V. | <u>HYDRAULIC CIRCUITRY</u> | <u>PAGE</u> |
|--------------|------------------------------------|--------------------|
| | A. Hydraulic Clamp | V- 1 |
| | B. Vibrator Drive | V- 1 |
| | C. Auger Drive | V- 3 |
| | D. Other | V- 3 |
| | Hydraulic Schematic | V- 4 |
| | E. Hydraulic Components List | V- 5 |
| VI. | <u>ELECTRICAL CIRCUITY</u> | |
| | A. Starting Diesel Engine | VI- 1 |
| | B. Stopping Diesel Engine | VI- 1 |
| | C. Safety Control System | VI- 2 |
| | D. Closing Hydraulic Clamp | VI- 3 |
| | E. Opening Hydraulic Clamp | VI- 3 |
| | F. Starting Vibrator | VI- 3 |
| | G. Stopping Vibrator | VI- 3 |
| | H. Other | VI- 4 |
| | Electrical Layout | VI- 5 |
| | Electrical Schematic | VI- 6 |
| | I. Electrical Components List | VI- 7 |
| VII. | <u>GENERAL DATA</u> | |
| | A. Abbreviations | VII- 1 |
| | B. Screws and Bolts | VII- 1 |
| | C. Serial Number Locations | VII- 2 |
| VIII. | <u>ORDERING PARTS</u> | |
| | A. Procedure | VIII- 1 |
| | B. Fitting Description Key | VIII- 2 |
| | Fitting Style Selector Chart - SC1 | VIII- 3 |
| | C. Hose Description Code | VIII- 4 |
| | D. Parts Identification | VIII- 5 |
| | Parts Lists and Drawings | VIII-6-VIII-57 |
| | E. Miscellaneous Accessories | VIII-58 |
| | F. Recommended Spare Parts | VIII-62 |
| | G. Recommended Tightening Torque | VIII-65 |



MODEL 44-50
VIBRATORY
DRIVER/EXTRACTOR



**MODEL 44-50
VIBRATORY
DRIVER/EXTRACTOR**

**OPERATING
INSTRUCTIONS**

A. GENERAL

The J&M Model 44 is a low-frequency vibratory pile driver/extractor designed to drive and extract sheet, pipe, timber and concrete piles, caisson pipe and H, I and wide-flange beams.

The Model 44 operates in a frequency range of 800 to 1600 vibrations per minute to provide maximum pile penetration rates in a wide variety of soils. The unit has an eccentric moment of 4400 inch-pounds (50.7 kg-M) and produces a maximum amplitude of 1.20 inch (30 mm).

The vibratory driver unit consists of two major components. (1) The vibrator with attached clamp and (2) the hydraulic power unit with control pendant.

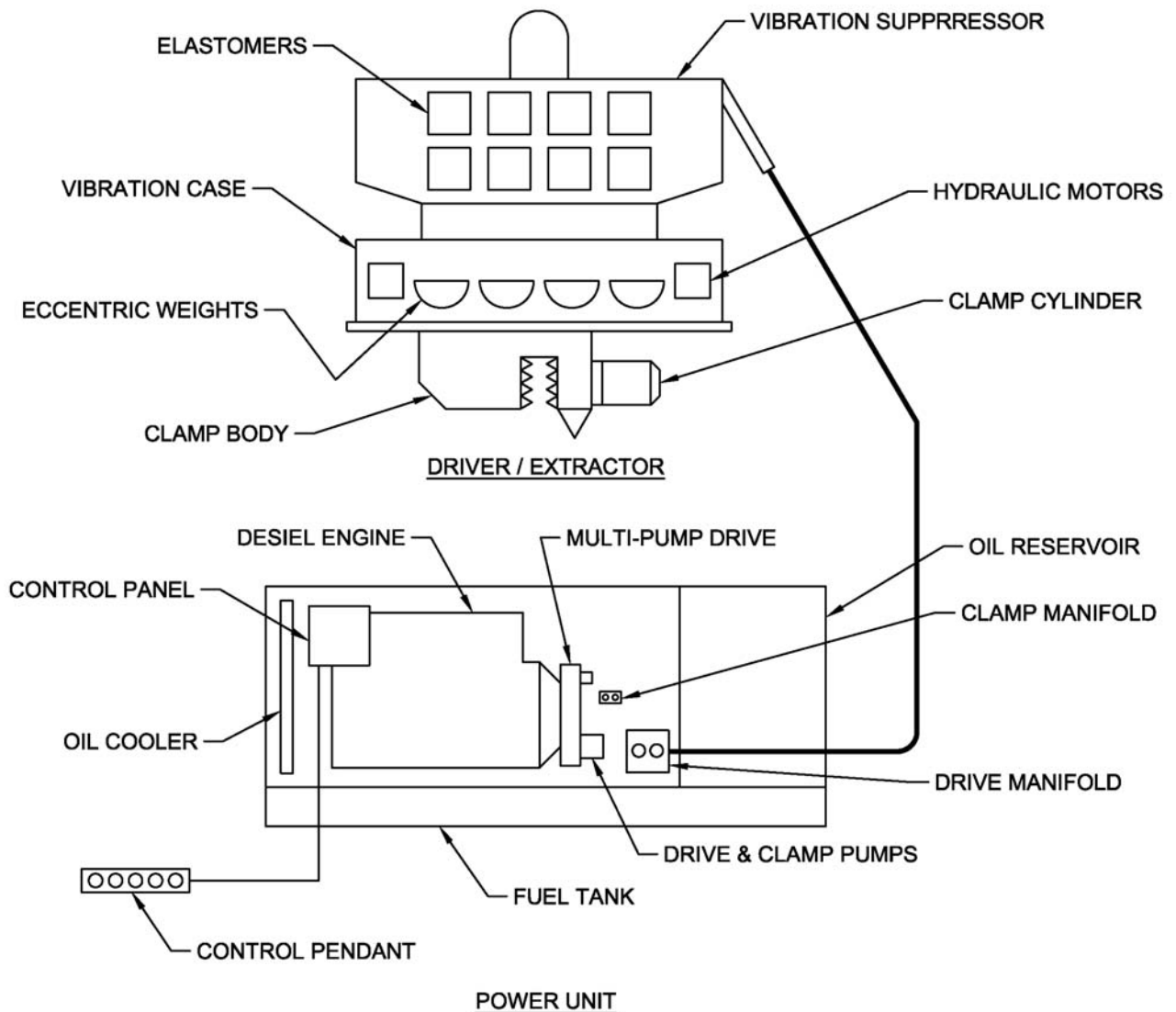



MODEL 44-50
VIBRATORY
DRIVER/EXTRACTOR

OPERATING INSTRUCTIONS

I. GENERAL DESCRIPTION

B. VIBRATOR

The vibrator consists of two major components; The vibration case and the vibration suppressor. The vibration case contains four eccentric weights which rotate in a vertical plane to create vibration. The eccentric weights are driven by two hydraulic motors. The vibration suppressor contains 16 rubber elastomers (20 or 24 optional) to isolate the vibration case from the crane line. The suppressor is designed for a maximum line pull of 80 tons (712kN) during extraction.

C. HYDRAULIC CLAMP

The hydraulic clamp attaches the vibrator to the pile. Five types of hydraulic clamps are available for the Model 44 vibrator. The Model 126 universal clamp will drive and extract most types of sheet piling, 14" (355mm) H-beams, and wide flange beams. The Model 127 Z-pile clamp is designed to drive and extract single Z-sheets and can also be used on Z-pile doubles. The Model 80 caisson clamps are used in pairs with either the 7-foot (2.13m) or 11-foot (3.35m) caisson beam to drive and extract pipe from 15" (381mm)ID to 136" (3454mm)OD. The Model 25 & 50 wood pile clamps are designed to drive and extract wood piles from 8" (203mm) OD to 18" (457mm)OD. The model 165 concrete pile clamp will drive and extract square concrete piles from 18" (457mm) to 24" (610mm).

INFORMATION

Consult J&M in your area for any other clamp questions regarding other than what is stated herein.

D. POWER UNIT

The Model 44 vibrator is powered by the J&M Model 580 Power pack. The 580 power pack is powered by a Caterpillar C-15 diesel engine. The engine develops 580 gross horsepower (433kW) at 2100 RPM, and is mounted on a tubular sub-base which serves as a fuel tank. The Power Unit and Vibrator are operated from the control panel or control pendant.

E. HOSES

A hydraulic hose bundle (multiple hoses) connects the hydraulic power unit to the vibrator unit.



**MODEL 44-50
VIBRATORY
DRIVER/EXTRACTOR**

**OPERATING
INSTRUCTIONS**

I. GENERAL DESCRIPTION

F. CONTROL PENDANT

The vibrator is operated by a hand-held control pendant. The control pendant has three, two-way switches (one with a light) and one push button. One switch (SLOW-FAST) raises and lowers the diesel engine speed. The second switch (REVERSE-FORWARD) starts and stops the vibrator. The other switch (OPEN-CLOSE) operates the hydraulic clamp. The light indicates that adequate clamping pressure exists for vibration to begin. The (red mushroom) push button (EMERGENCY STOP) shuts down the diesel engine instantly, in the event of an emergency. Note: Controls are duplicated on the control panel in case the pendant is damaged. (See pg. III-5, Section E-e)

G. SPECIFICATIONS

1. Constant improvement and engineering progress make it necessary that we reserve the right to make specification changes without notice.

INFORMATION Always consult J&M in your area for current or additional information you may require.

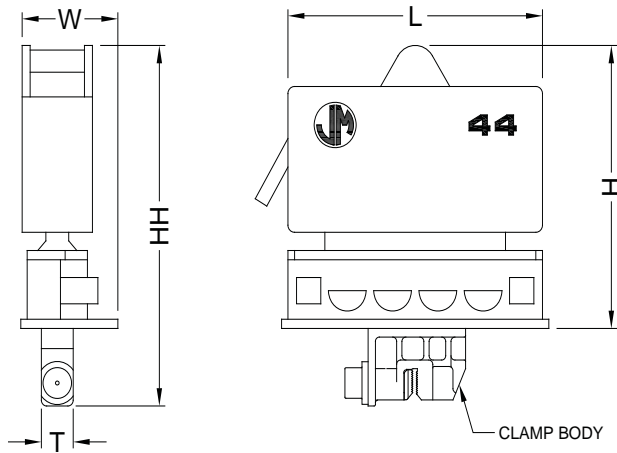

2. Model 44-50 VIBRATOR (with hydraulic clamp)

| | |
|-------------------------------|-------------------------|
| Type | Hydraulic |
| Eccentric Moment | 4400 In-lbs. (50.7kg-M) |
| Frequency | 800-1600 VPM |
| Amplitude | 1.20 in. (30 mm) |
| Pile Clamping Force..... | 125 Tons (1112kN) |
| Max. Line Pull for | |
| Extraction | 80 Tons (712kN) |
| Weight Bare | 12,400 lbs. (5,625kg) |
| Weight with 126 Clamp | 14,800 lbs. (6,713kg) |
| Length [L] | 97 in. (241cm) |
| Width [W] | 22 in. (56cm) |
| Throat Width [T] | 14.25 in. (36cm) |
| Height with Clamp [HH]..... | 110 in. (280cm) |
| Height without clamp [H]..... | 83 in. (211cm) |

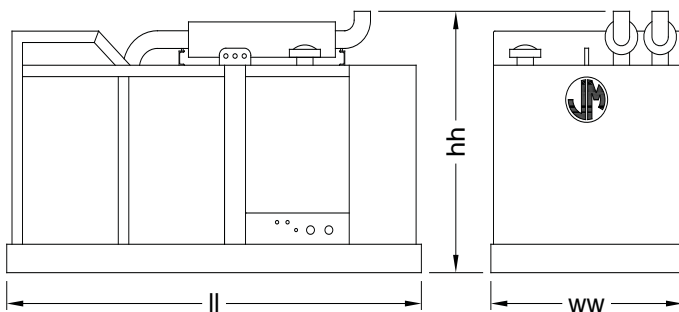

3. MODEL 580 POWER UNIT

| | |
|-----------------------------|-----------------------|
| Type | Diesel |
| Engine | CAT C-15 |
| Horsepower (2100 RPM) | 580(433kW) |
| Weight | 16,500 lbs. (7,484kg) |
| Length[II] | 158in. (401cm) |
| Width [ww]..... | 73in. (185cm) |
| Height [hh]..... | 95 in. (241cm) |



MODEL 44-50
VIBRATORY
DRIVER/EXTRACTOR

OPERATING INSTRUCTIONS



MODEL 44-50
VIBRATORY
DRIVER/EXTRACTOR

OPERATING INSTRUCTIONS

II. PREPARATION FOR OPERATION

A. GENERAL



When unloading and unpacking the vibratory driver, use extreme care. For your protection, make a thorough inspection of the unit immediately on delivery. In case of any damage or shortage, notify the transit agent at once and have the delivering carrier make a notation on the freight bill.

B. SAFETY PRECAUTIONS

Safety is very important and is everyone's responsibility that operates this equipment or services this equipment.



Use the following safety precautions as a general guide to safe operations, when in doubt consult J&M before proceeding with any operation that may produce an unsafe result. These safety guidelines do not constitute all possible safety issues that may occur during operation or maintenance.

1. Read this manual thoroughly before operating or working on the equipment.
2. Read and follow any safety instructions in the CATERPILLAR engine operators manual.
3. Only well trained and experienced personnel should attempt to operate or maintain this equipment.
4. Never adjust, lubricate or repair the unit when it is in operation, or lifted above ground level.
5. Never remove, paint over or cover warning or safety labels. If labels become damaged or unreadable, replace immediately.
6. All personnel should wear approved safety clothing, including **HARD HATS, SAFETY SHOES, SAFETY GLASSES** and **HEARING PROTECTION** when in the vicinity of this machinery.
7. Do not stand any closer to this equipment than necessary when it is in operation. Parts may loosen and fall. Never stand under operating, or elevated, equipment.
8. When maintaining or repairing the equipment, never substitute parts not supplied, or approved in writing, by J&M.
9. Do not weld, or flame cut, on this equipment.
10. Never use or store flammable liquids on or near the engine.
11. Insure that all lifting equipment, including cranes, wire rope, slings, hooks, shackles, etc., are properly sized for the worst case loads anticipated during operations.
12. If there are any questions about the weights, specifications, or performance of the unit, contact J&M before handling or operating the equipment.
13. If the equipment is to be used for anything other than driving or extracting plumb piles, contact J&M before using the unit.
14. Check wire rope clips for tightness, and check wire ropes for wear, daily.



**MODEL 44-50
VIBRATORY
DRIVER/EXTRACTOR**

**OPERATING
INSTRUCTIONS**

II. PREPARATION FOR OPERATION

B. SAFETY PRECAUTIONS (CONTINUED)

15. Insure that ground vibrations will not damage or collapse adjacent structures or excavations.
16. Remove all tools, parts and electrical cords before starting the unit.
17. When operating in an enclosed area, pipe exhaust fumes outside. Continued breathing of exhaust fumes may be fatal.
18. When servicing batteries, do not smoke or use open flames in the vicinity. Batteries generate explosive gas during charging. There must be proper ventilation when charging batteries.
19. When filling fuel tank, do not smoke or use open flame in the vicinity.
20. If abnormal equipment operation is observed, discontinue use immediately and correct the problem. Do not leave the equipment control pendant (radio control) unattended.
21. Store oily rags in approved containers, and away from engine exhaust system.
22. Make sure that the vibrator is OFF before starting the power unit engine.
23. Do not adjust, or set, hydraulic pressures higher or lower than those specified in this manual.
24. Never operate this equipment with hydraulic hoses that are damaged or "kinked". Replace damaged hoses immediately.
25. Do not lift, or support, hydraulic hoses with wire rope slings.
26. Never attempt to connect quick disconnects when the power unit is running.
27. Do not pull on, or attempt to move equipment, with hydraulic hoses.
28. Do not attempt to locate hydraulic leaks with your hands. High pressure hydraulic leaks can penetrate the skin, causing severe damage, blood poisoning and infection. Do not attempt to repair leaks while the equipment is in operation.
29. Do not attempt to tighten, or loosen, fittings or hoses when the machine is in operation.
30. Power unit must always be placed on level, stable, ground.
31. Do not remove power unit heat shields, or operate power unit without heat shields. Severe fires may result.
32. A properly maintained fire extinguisher, suitable for oil fires, must be kept in the immediate vicinity of equipment operations.
33. When moving or transporting this equipment, insure that the vehicle or vessel is of sufficient capacity to handle the load, and that the equipment is properly tied down.
34. When moving or transporting this equipment, be sure that quick disconnect dust caps are tight, and that cap safety cables are in place. Be sure that all equipment parts are tight, or properly secured, before shipment. Unsecured parts may vibrate loose and fall, during transport, causing injury or property damage.
35. Keep crane boom, piles, leads, wire rope and other equipment at least 15' (5M) from electrical power lines, transformers and other electrical equipment, or at such distance as required by applicable safety codes.



**MODEL 44-50
VIBRATORY
DRIVER/EXTRACTOR**

**OPERATING
INSTRUCTIONS**

II. PREPARATION FOR OPERATION

B. SAFETY PRECAUTIONS (CONTINUED)

36. Rounded or damaged bolt heads or nuts should be replaced so that proper torque values may be obtained. Proper torque values are necessary to prevent parts on this equipment, leads and crane boom from loosening and falling. Refer to Torque Chart, in this manual, for proper values.
37. Do not use the vibrator clamp to move piles we recommend using a safety line in case of loss of hydraulic pressure.
38. Never clamp vibrator to pile and disconnect the crane line. Loss of hydraulic pressure could cause vibrator to fall. Lay vibrator down when not in use.
39. When extracting piles, always attach a safety line between pile and crane hook.
40. When extracting piles, check crane load/radius tables to be sure crane capacity is adequate for maximum allowable extraction pull.
41. When extracting piles, or any other driving operations, always be sure that the crane line is aligned with the centerline of the pile. Do not side load crane boom or vibrator. Dangerous crane boom, or vibrator, damage may result.
42. When extracting piles, do not exceed the capacity of the vibrator suppressor. Continued operation against the safety stops will cause damage to the crane boom and the vibrator.
43. Never induce line pull on a vibrator before starting the unit in vibration. Always start both driving and extraction of piles with a slack line.
44. Keep hands away from clamp jaws.
45. Keep hands away from vibrator suppressor during operation. Clearances may change causing pinch points.
46. Do not run vibrator unless clamp jaws are closed.
47. Use tag line to control vibrator whenever possible.
48. When driving "batter" piles, insure that the leads, and crane boom, have sufficient bending strength to handle the worst case load. Consult J&M.

REMEMBER, SAFETY IS EVERYONE'S BUSINESS.



MODEL 44-50
VIBRATORY
DRIVER/EXTRACTOR

OPERATING INSTRUCTIONS



MODEL 44-50
VIBRATORY
DRIVER/EXTRACTOR

OPERATING INSTRUCTIONS

II. PREPARATION FOR OPERATION

C. RIGGING OF VIBRATOR

A steel wire rope sling must be connected to the lifting pin of the vibration suppressor. The required strength of this sling depends on the capacity of the crane and the work to be carried out. A safety factor of five is recommended. Several turns of a smaller diameter cable will usually last longer than one turn of a larger diameter cable.



All rigging of either the hydraulic power unit or vibrator must be done in accordance with standard rigging guide lines set forth in ASTM standards; J&M does not assume responsibility for incorrect rigging or procedures.

D. CONNECTION OF HYDRAULIC CLAMP

The vibrator is usually shipped with the hydraulic clamp already attached.

If the clamp is not attached, it will be necessary to attach it to the bottom of the vibrator. Orient the clamp to the vibrator with the clamp cylinder end (movable jaw) at the same end of the vibrator as the hose chute is mounted. All eight (1.5-6UNC x 5.00) bolts must be in place and torqued to approximately 2800 ft-lbs.

For caisson work, the caisson beam must be attached to the bottom of the vibrator and tightened as above. Then slide the clamps into position on the caisson beam.



**MODEL 44-50
VIBRATORY
DRIVER/EXTRACTOR**

**OPERATING
INSTRUCTIONS**

II. PREPARATION FOR OPERATION

E. CONNECTION OF HYDRAULIC HOSES

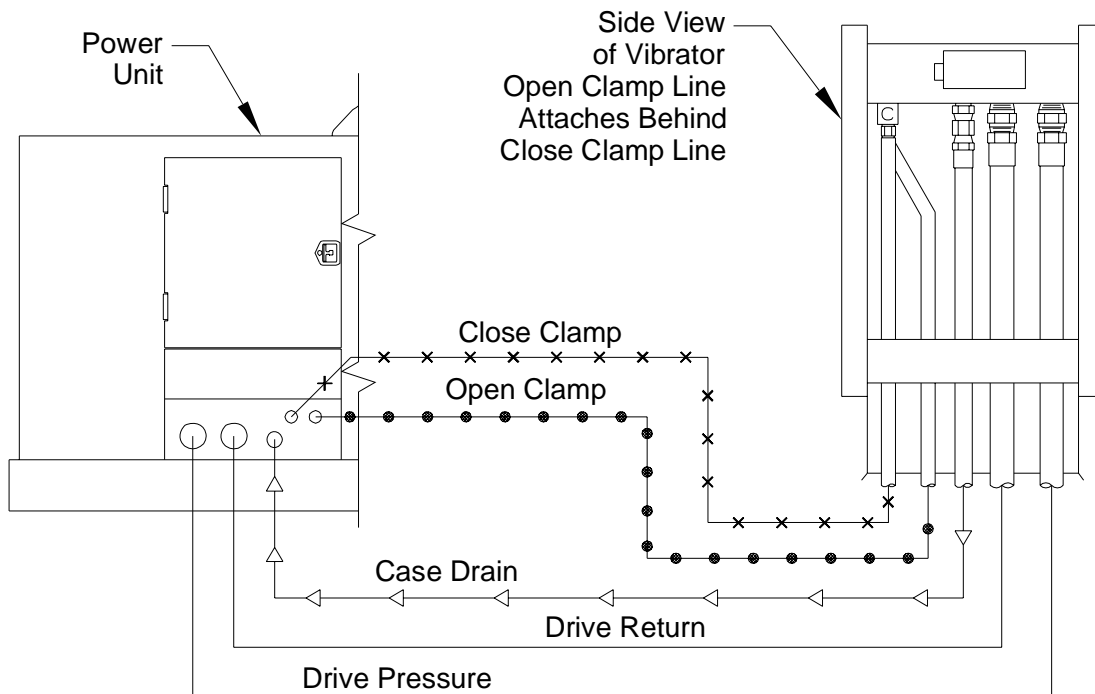

(Fig. 1)

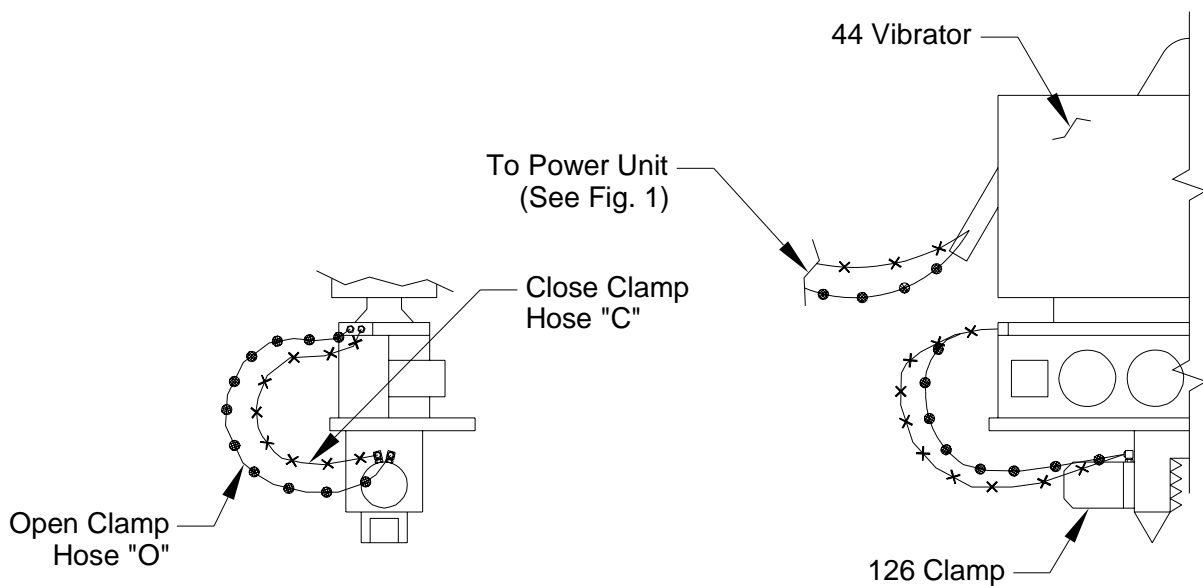

(Fig. 2)



MODEL 44-50
VIBRATORY
DRIVER/EXTRACTOR

OPERATING INSTRUCTIONS

II. PREPARATION FOR OPERATION

E. CONNECTION OF HYDRAULIC HOSES

1. Connection of hoses at power unit.

a. The vibrator and hydraulic clamp are connected to the power unit by five hydraulic hoses (Fig. 1) on the previous page.



The power unit must be shut down during connection of the hydraulic hoses.

b. The hoses connect to the power unit with quick-disconnect couplers. Hose couplers are arranged to insure correct connections at the power unit. See the diagram (Fig. 1) for correct hose connection.

c. Clean couplers with a lint-free cloth before making connections.



Do not use engine starting fluid to clean quick disconnects, this will damage the seals and result in an oil leak.

d. Make sure that the couplers are fully run up, and hand tightened only, do not use wrenches to over tighten.

2. Connection of hoses at vibrator.

a. The vibrator is usually shipped with the hoses attached to the vibrator. If the hoses have been shipped separately, they must be connected in the field. Fig. 1 shows the correct arrangement of the five hoses connecting the power unit to the vibrator.



Starting the vibrator with the hoses reversed will result in low power or possible ruptured hoses.

b. The vibrator is usually shipped with the hydraulic clamp and hoses attached. If the clamp has been shipped separately, the two hoses connecting the clamp to the vibrator must be connected. (Fig. 2) shows the correct arrangement of these hoses.

For caisson clamps, four hoses must be connected. The two connections on the opposite end of the vibrator are reversed from the positions shown in Fig. 2. Both ends of the vibrator are stamped with an "O" and a "C" to insure correct connection. The clamp connections are also stamped with an "O" and a "C".



**MODEL 44-50
VIBRATORY
DRIVER/EXTRACTOR**

**OPERATING
INSTRUCTIONS**

III. PREPARATION FOR OPERATION

F. BLEEDING HYDRAULIC CLAMP HOSES

1. When the vibrator and hydraulic clamp are shipped with all hoses attached (between vibrator and clamp and five main hoses connected to the vibrator), the hoses are usually full of fluid and may be used immediately. However, if any of the clamp hoses are connected at the jobsite or if air is present in hoses, they must be bled prior to operation.
2. Read SECTION III - OPERATING INSTRUCTIONS.



Use caution when bleeding any hydraulic lines, even low hydraulic pressure can cause injury to personnel.

3. Start and warm up the diesel engine in accordance with SECTION III-C - STARTING AND WARMING UP ENGINE.
4. With the engine warmed-up and running at 1500 RPM, loosen the close-clamp line at the hydraulic clamp. Turn the clamp switch on the control pendant to CLOSE. Wait until fluid flows from the connection at the hydraulic clamp. When fluid flows without air, tighten the connection.
5. After the line has been bled, alternately turn the clamp switch to CLOSE and OPEN to insure that the clamp is working properly. It may be necessary to bleed the line more than once. The open-clamp line may also require bleeding.

G. FILLING VIBRATOR PRESSURE HOSE

1. The vibrator is usually shipped with the vibrator hydraulic hoses full of fluid and the unit may be used immediately. However, if the pressure hose has been removed from the vibrator, the hose should be allowed to fill with hydraulic fluid prior to full speed operation.
2. Read SECTION III - OPERATING INSTRUCTIONS.
3. Start and warm up the diesel engine in accordance with SECTION III-C - STARTING AND WARMING UP ENGINE. Hold the vibrator in a vertical position.
4. With the engine warmed up and running at 1000 RPM, turn and hold the vibrator switch REVERSE. The hoses will fill in approximately 5 minutes.



If vibration begins in the vibrator, stop immediately and recheck hose connections.



MODEL 44-50
VIBRATORY
DRIVER/EXTRACTOR

OPERATING
INSTRUCTIONS

III. OPERATING INSTRUCTIONS

CONTROL PANEL WITH CONTROL PENDANT

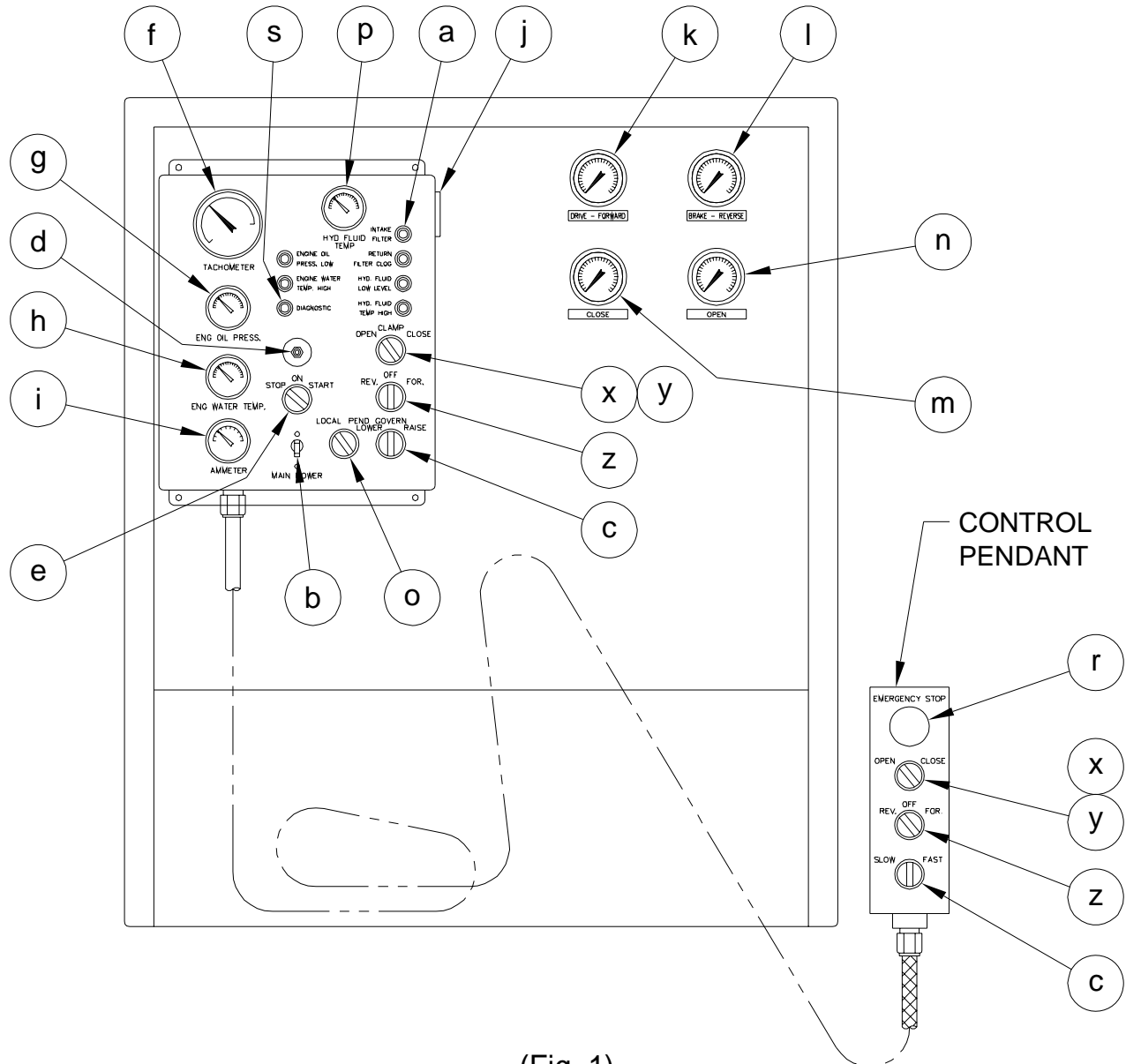

(Fig. 1)



**MODEL 44-50
VIBRATORY
DRIVER/EXTRACTOR**

**OPERATING
INSTRUCTIONS**

III. OPERATING INSTRUCTIONS

A. COMPLETION OF SET-UP AND MAINTENANCE

1. Complete all preparation as described in Section II.
2. Read Section IV - MAINTENANCE AND ADJUSTMENTS and perform any required maintenance.

B. CONTROL PANEL

1. The control box (Fig. 1, page III-1) at the side of the power pack contains the controls and gages for the diesel engine, vibrator, and the OPERATION AND MAINTENANCE INSTRUCTIONS.
2. Control panel contains the following controls and gages:
 - a. Shutdown indicator lights (6) See notes below.
 - b. Main power switch (Circuit Breaker) - on/off switch for 24 volt electrical power.
 - c. Engine throttle.
 - d. Engine shut-down reset button - on start must be held in until oil pressure exceeds 30 PSI.
 - e. Engine "ON/OFF/START" switch - for diesel engine.
 - f. Engine tachometer.
 - g. Engine oil pressure gage.
 - h. Engine water temperature gage.
 - i. Engine ammeter.
 - j. Engine hourmeter.
 - k. Pressure gage - (Drive - Forward).
 - l. Pressure gage - (Brake - Reverse).
 - m. Pressure gage - (Close).
 - n. Pressure gage - (Open).
 - o. Local-Pendant switch.
 - p. Hydraulic Fluid temperature gage.
 - r. Emergency Stop - Push to stop engine
 - s. Diagnostic light.
 - x. Clamp light.
 - y. Clamp switch.
 - z. Vibrator switch.

- Notes:
1. Engine Oil Pressure shutdown indicator - comes on if the engine has been shut down automatically due to engine oil pressure being low.
 2. Engine Water Temperature shutdown - comes on if the engine has been shut down automatically due to engine water overheating.
 3. Engine Overspeed shutdown indicator - comes on if engine has been shut down automatically due to the engine being run at excessively high RPM's.



MODEL 44-50
VIBRATORY
DRIVER/EXTRACTOR

OPERATING INSTRUCTIONS

III. OPERATING INSTRUCTIONS

B. CONTROL PANEL (CONTINUED)

4. Filter Clogged shutdown indicator - comes on if the engine has been shut down automatically due to the hydraulic oil return filter being clogged.
5. Hydraulic Oil Level Low shutdown indicator comes on if engine has been shut down automatically due to low hydraulic oil level in the reservoir.
6. Hydraulic Oil Temperature High shutdown indicator - comes on if the engine has been shut down automatically due to high hydraulic oil temperature.

The Diagnostic light indicates when an engine fault code is flashing a for CAT software.



3. The OPERATION AND MAINTENANCE INSTRUCTIONS on the control panel are there as reminders only. They are not complete and therefore not intended to substitute for a thorough understanding of this Operating Manual.

C. STARTING AND WARMING UP ENGINE

1. Before starting the engine, read the CATERPILLAR OPERATION GUIDE carefully. Follow the engine starting, operating and maintenance procedures in that manual.
2. The diesel engine should not be started if the temperature of the hydraulic fluid is below 0°F(-18°C). The temperature may be read on the gage on the hydraulic reservoir. If ambient temperatures below 0°F(-18°C) are anticipated, an immersion heater for the hydraulic fluid is available. Consult J&M for details.
3. The MAIN POWER SWITCH on the control panel should be ON. The vibrator switch (FOR/REV) on the control pendant should be in the neutral position.
4. Hold SHUTDOWN RESET button in and turn the ENGINE START switch to START position. If the engine fails to start after 30 seconds of cranking, allow the starter to cool for two minutes before repeating the starting procedure.
5. As the engine starts, release the ENGINE START switch. It will return to the RUN position.
6. Adjust the throttle until the engine is running at 1500 RPM and allow to warm-up for five minutes.
7. Allow the temperature of the hydraulic fluid to come up to at least 30°F(-1°C) before starting vibrator.



MODEL 44-50
VIBRATORY
DRIVER/EXTRACTOR

OPERATING INSTRUCTIONS

III. OPERATING INSTRUCTIONS

D. WARMING HYDRAULIC FLUID

1. The vibrator should not be operated at full speed if the temperature of the hydraulic fluid is below 70°F(21°C). The HYDRAULIC FLUID COLD light on the control panel will be on if fluid temperature is below 70°F(21°C). Also check gage on reservoir.
2. If temperature of the hydraulic fluid is below 70°F(21°C), set the diesel engine at 1500 RPM and run the vibrator at reduced speed until the temperature of the hydraulic fluid exceeds 70°F(21°C). The Hydraulic Fluid Cold light will then go off.
3. When the engine is warmed up and hydraulic fluid temperature is at least 70°F(21°C), full speed operation may begin. Adjust the throttle so the engine is running at 2100 RPM unloaded. The engine should maintain about 2100 RPM under load.



Do not operate the vibrator if hydraulic fluid temperature exceeds 180°F(82°C) as this may damage hydraulic components.

E. OPERATION OF CONTROL PENDANT

1. The operation of the vibratory driver is controlled by the control pendant. The control pendant is connected to the control panel with 50 feet of electrical cable to permit operation from any advantageous position to view the vibrator. (Consult J&M for pendant extensions)
2. The pendant has three, two-way switches, one with an indicator light and an Emergency Stop button.
 - a. To Clamp to Pile:

Position vibratory driver on pile. Turn the clamp switch on the pendant to CLOSE. The CLAMP light on the pendant will come on when the hydraulic clamp has achieved adequate pressure to permit vibration to begin. The light should normally come on in a few seconds.

- b. To Start Vibration:

Turn the vibrator switch to FORWARD.

NOTE: The vibrator switch reads FORWARD/REVERSE instead of START/STOP because the Model 580 power unit also operates J&M earth augers.



Do not turn the switch to FORWARD until the CLAMP light in the pendant comes on, indicating adequate clamping pressure.



MODEL 44-50
VIBRATORY
DRIVER/EXTRACTOR

OPERATING INSTRUCTIONS

III. OPERATING INSTRUCTIONS

E. OPERATION OF CONTROL PENDANT (CONTINUED)

c. To Stop Vibration:

Turn the vibrator switch to OFF.

NOTE: Accidentally turning the switch to REVERSE normally has no effect and will not cause damage.

d. To Unclamp from Pile:

Turn the CLAMP switch to OPEN to release the hydraulic clamp so that the vibrator can be moved from the pile. Hold the CLAMP switch in the open position until the jaws are fully open.

 **DANGER** Do not turn the switch to OPEN until a visual check indicates that vibration has stopped.

e. To change engine speed:

Turn the Throttle switch (SLOW-FAST) to SLOW and the engine speed will decrease. Turn the switch to FAST and the engine speed will increase. Momentarily turning the throttle switch to FAST or SLOW during operations will adjust engine speed, and therefore vibrator speed, to facilitate the desired penetration rate.

f. Emergency stop button:

Push the EMERGENCY STOP button in and all operating functions will cease to operate. Diesel engine and vibrator will stop immediately.

g. If the control pendant is damaged or the pendant line is cut, you may still operate the vibrator by using the control switches on the control panel (See Fig. 1 on page III-1 items C, Y, Z). On the control panel there is a switch labeled "LOCAL-PENDANT". Turn the switch to LOCAL and the switches on the control panel will be functional, and the Control Pendant will be disabled.



MODEL 44-50
VIBRATORY
DRIVER/EXTRACTOR

OPERATING INSTRUCTIONS

III. OPERATING INSTRUCTIONS

F. CHANGING FREQUENCY

1. In order to provide maximum flexibility in achieving optimum pile penetration and extraction rates, the frequency of the vibratory driver is adjustable.
2. The frequency can be varied from 800 to 1600 vibrations per minute by changing engine speed. Engine speed is changed with the ENGINE THROTTLE switch (SLOW-FAST) on the control panel or on the remote control pendant. Vibrator frequency corresponds to engine speed according to the table shown below:

| <u>ENGINE RPM</u> | <u>VIBRATOR VPM</u> |
|-------------------|---------------------|
|-------------------|---------------------|

| | |
|------|------|
| 2100 | 1600 |
| 2000 | 1525 |
| 1700 | 1300 |
| 1500 | 1150 |
| 1050 | 800 |

G. SHUT DOWN

1. Stop the vibrator.
2. Allow the diesel engine to run for five minutes at 1500 RPM.
3. Reduce speed to low idle for about thirty seconds.
4. Stop the engine by turning the ENGINE START switch to OFF. (Engine may also be stopped by pushing in the EMERGENCY STOP button on the Control Pendant.)



If the diesel engine is shut down while the vibrator is clamped to a pile, the clamp check valve will keep the vibrator clamped to the pile. However, system leakage could result in a loss of clamp pressure over time. Therefore, it is not recommended to leave the vibrator clamped to a pile when the diesel engine is not running.

IV. MAINTENANCE AND ADJUSTMENTS

A. GENERAL

Preventive maintenance includes normal servicing that will keep the vibratory driver, clamp and power unit in peak operating condition and prevent unnecessary trouble from developing. This servicing consists of periodic lubrication and inspection of the moving parts and accessories of the unit.

Lubrication is an essential part of protective maintenance, controlling to a great extent the useful life of the unit. Different lubricants are needed and some components in the unit require more frequent lubrication than others. Therefore, it is important that the instructions regarding types of lubricants and frequency of their applications be closely followed.

To prevent minor irregularities from developing into serious conditions that might involve shut-down and major repair, several other services or inspections are recommended for the same intervals as the periodic lubrications. The purpose of these services or inspections is to assure the uninterrupted operation of the unit.

Thoroughly clean all lubrication fittings, caps, filler and level plugs and their surrounding surfaces before servicing. Prevent dirt from entering with lubricants and coolants. The intervals given in the schedule are based on normal operation. Perform these services, inspections, etc., more often as needed for operation under abnormal or severe conditions.

B. DAILY

1. Check the entire unit prior to and during set-up each day or at the beginning of each shift.
2. Prior to starting the power unit or at the beginning of each shift, check the following items:
 - a. Visibly inspect all bolts, nuts and screws, including the bolts fastening the hydraulic clamp to the vibration case, to insure they are tight.

CAUTION Vibration loosens bolts - check carefully.

- b. Tighten bolts holding gripping jaws in hydraulic clamp.
- c. Grease plunger in hydraulic clamp with any good multi-purpose grease.
- d. Check the oil level in the vibration case and add oil if required. The oil level should be in the middle of the sight glass. Change oil if milky or contaminated. DO NOT OVERFILL
- e. Check the fluid level in the hydraulic reservoir and refill if necessary.

CAUTION It is absolutely imperative that no dirt or other impurities be permitted to contaminate the hydraulic fluid. Any contamination will drastically shorten the life of the high-pressure hydraulic system.

IV. MAINTENANCE AND ADJUSTMENTS

B. DAILY (CONTINUED)

- f. Visually check all hoses for signs of damage or cuts that might cause hose failure during operation. Be sure all connections are tight, especially the quick-disconnect couplers.
 - g. Visually inspect all suppressor elastomers and elastomer bolts.
 - h. Electrical components need no maintenance except periodic wiping with a clean, dry, lint-free cloth to remove dust.
 - i. Perform all daily maintenance checks and lubrication indicated in the CATERPILLAR OPERATION GUIDE.
3. After engine start-up, check the following:
- a. Check all hydraulic hoses for leaks. Make sure they hang freely with no kinks.
 - b. Check pump and all hydraulic manifolds for leaks.
 - c. Check the filter indicators. 0-17psi = Filter Clean, 18-23psi = Change Filter, 24 + psi = Filter Clogged The return filter on the power pack must be checked with the diesel engine running at full speed.

C. 100 HOURS, 500 HOURS AND OTHER

1. Every 100 hours, drain and add new lubricant in the vibration case.
2. Perform all maintenance checks and lubrication indicated in the CATERPILLAR OPERATION GUIDE.
3. After the first 100 hours, drain and replace the lubricant in the multi-pump drive. There after change every six months or 2000 hours, which ever comes first.

D. ANNUALLY

1. Have the hydraulic fluid tested by a local hydraulic service center or oil company. Replace if required.

INFORMATION The frequency with which hydraulic fluid requires changing depends both on the condition of the fluid and the operating conditions involved. The most accurate method for determining how often fluid should be changed is to have a laboratory fluid analysis done periodically.

2. See Caterpillar OPERATION GUIDE.

IV. MAINTENANCE AND ADJUSTMENTS

E. SEVERE CONDITIONS

The servicing intervals specified are based on normal operating conditions. Operation under severe or unusual conditions will require some adjustments in servicing intervals.

1. When the average temperature is above 80°F(26°C) or below -10°F(-23°C), reduce service time intervals by one-half of those specified above.
2. When operating in the presence of dust or sand, reduce service time intervals by one-half of those specified.
3. When operating in excess of twelve hours per day, reduce service time intervals by one-half of those specified.
4. When operating in air with high moisture or salt, the servicing intervals need not usually be changed. However, the unit should be inspected weekly to determine if additional servicing be required. Also, have hydraulic fluid tested quarterly.
5. For extended inactive periods, the engine should be started at least once a week and run until thoroughly warm. Servicing time intervals may be extended from those specified, but for actual time intervals, contact your local Caterpillar dealer, especially during lengthy storage periods.

F. LUBRICATION

1. Crankcase (Diesel Engine)
 - a. Follow the engine manufacturer's maintenance schedule and the lubricating oil specifications outlined in the CATERPILLAR OPERATION GUIDE.
 - b. The lubricant shall meet the performance requirements of API Service Classifications CH-4.
 - c. New engines are shipped with Caterpillar SAE 15W-40 but the following multi-grade crankcase oils are recommended for use or replacement in normal operation (10°F to 90°F) (-12°C to 32°C).

IV. MAINTENANCE AND ADJUSTMENTS

F. LUBRICATION (CONTINUED)

| | | |
|-----------|--------|------------------|
| ASHLAND | 15W-40 | 400M + HDT |
| AMOCO | 15W-40 | 300 |
| ARCO | 15W-40 | Fleet S3 Plus |
| BP | 15W-40 | Vanellus C Extra |
| CHEVRON | 15W-40 | Delo 400 |
| CITGO | 15W-40 | C500 Plus |
| CONOCO | 15W-40 | Fleet Supreme |
| EXXON | 15W-40 | XD3 |
| GULF | 15W-40 | Super Duty Plus |
| MOBIL | 15W-40 | Delvac Super |
| PHILLIPS | 15W-40 | Super HD II |
| SHELL | 15W-40 | Rotella T |
| SUN | 15W-40 | Sunfleet Super C |
| TEXACO | 15W-40 | Ursa Super Plus |
| UNION | 15W-40 | Guardol |
| VALVOLINE | 15W-40 | All Fleet |

- d. For operation in extreme sub-zero climate, refer to the CATERPILLAR OPERATION GUIDE Crankcase Lubricating Oils or contact the nearest Caterpillar representative. (CAT bulletin #SEBU5898-06)

2. Hydraulic System

To maintain the maximum operating efficiency in the precision parts of the hydraulic system, it is extremely important to eliminate factors which can cause breakdowns or unsatisfactory performance in the system. Among the most common of these factors are rust, corrosion, contamination and products of oil deterioration. Most problems can be minimized or avoided simply by maintaining a disciplined preventive maintenance program.

Some simple steps to follow as part of that program are:

- Keep stored oil dry and clean at all times and always store in clean containers.
- Always clean tools, spouts, lids, funnels, etc. when used in conjunction with the transfer of oil.
- Never put dirty oil into the hydraulic system. Use only clean, uncontaminated oil of the types recommended below. Never return to the system any fluid which has leaked out.

NOTE: Foreign material in the hydraulic system can drastically effect the life and operation of many hydraulic component parts.

- Clean or replace filter elements at the first indication that they are dirty or ineffective.

IV. MAINTENANCE AND ADJUSTMENTS

F. LUBRICATION (CONTINUED)

Mixing of different manufacturers' hydraulic fluid is not recommended.

INFORMATION

New power units are shipped with Terresolve Invirological 146 Hydraulic oil. This oil is non-toxic and will not harm soil or water and is biodegradable. Adding any other oil from the list below, will contaminate the Terresolve oil and the system will no longer be environmentally friendly.

Should the customer choose to use an alternate oil, the following recommendations may be used when replacing fluid in the hydraulic system.

FIRST Preference Group:

| | |
|------------|-------------------|
| TERRESOLVE | Invirological 146 |
| CHEVRON | Clarity AW46 |
| MOBIL | DTE-15 |
| SUN | 2105 |

SECOND Preference Group:

| | |
|----------|----------------|
| ARCO | Duro AW46 |
| CHEVRON | Hydraulic AW46 |
| PHILLIPS | Magnus A46 |
| SHELL | Tellus 46 |

THIRD Preference Group:

| | |
|--------|-------------------|
| BORON | Energol HLP46 |
| CITGO | A.W. Hydraulic 46 |
| CONOCO | Super 46 |
| EXXON | Nuto H46 |
| GULF | Harmony 46AW |
| SUN | Sunvis 846 |
| TEXACO | Rando HD AZ46 |
| UNION | Unax AW46 |

INFORMATION

Whenever fluids from the second preference group are used, it is necessary to test the oil more often to insure that viscosity remains within recommended limits while in service. Using fluids from the third preference group requires even a more discerning inspection than use of fluids from the second group.

The recommended fluids were chosen based on the hydraulic system operating temperature range being 5°F (-15 °C) (cold ambient start-up) to 180°F (82°C) (maximum operating).

IV. MAINTENANCE AND ADJUSTMENTS

F. LUBRICATION (CONTINUED)

INFORMATION

When operating in arctic conditions, it is recommended to use a heater to pre-heat the oil prior to starting. Contact J&M for other arctic operating procedures. It may also be necessary in extremely cold or hot climates to use a different viscosity oil which is better adapted to adverse conditions. Contact the nearest oil supply representative for suggested procedures.

TERRESOLVE Invirological 146 hydraulic fluid is available from J&M in five gallon cans. See SECTION VIII - ORDERING PARTS, page VIII-58.

3. Vibration Case

The fluid level is easily read through the sight glass located at the lower center of the vibration case on the motor side. Lubricating oil may be added when necessary, through either of the holes in the vibration case top plate after removing the 1" pipe plugs. To drain the case, remove a 1" pipe plug at either end of the base plate. Tilt the case for complete drainage.

4. Multi-Pump Drive Adapter

The fluid level is easily checked by removing the 1/4 inch hex head pipe plug on the right side of the Multi-pump Drive Adapter. Lubricating oil should be to this level. If low, lubricating oil may be added by removing the 1/2 inch socket head pipe plug located on the left side of the Multi-pump Drive Adapter. Draining the lubricating oil may be done by removing the 1/2 inch socket head pipe plug on the bottom of the Multi-pump Drive Adapter.

5. The preferred lubricating oil for J&M vibration cases and multi-pump drive adapters is "High Moly" oil (Schaeffer 268). Longer intervals between fluid changes and fewer maintenance hours spent on mechanical service can generally be realized with this fluid.

Therefore, whenever the "first preferred" oil is not available, or desired, and an alternate fluid is selected, it will be necessary to test and/or change the oil at shorter intervals.

Extensive tests have indicated that the use of Schaeffer 268 results in cooler operation and extended bearing and gear life.

**MODEL 44-50
VIBRATORY
DRIVER/EXTRACTOR**

**OPERATING
INSTRUCTIONS**

IV. MAINTENANCE AND ADJUSTMENTS

F. LUBRICATION (CONTINUED)

- a. The vibration case lubricants installed at the factory are SCHAEFFER 268 but the following gear lubes may be used when changing lubricants:

FIRST Preference Group:

SCHAEFFER 268

SECOND Preference Group:

| | |
|----------|---------------------|
| MOBIL | SHC-629 |
| BP | Gearep 140 |
| CHEVRON | Gear Comp. NL460 |
| CITGO | Premium MP 85W-140 |
| CITGO | Standard MP 85W-140 |
| GULF | Lub 85W-140 |
| PHILLIPS | MP 85W-140 |
| SHELL | Omala S2G 460 |
| SUN | Sunep 1110 |

THIRD Preference Group (Natural Petroleum Base):

| | |
|-----------|------------------|
| CHEVRON | Perma Gear EP140 |
| CONOCO | EP 460 |
| EXXON | Spartan EP 460 |
| PHILLIPS | AP 140 |
| TEXACO | Meropa 460 |
| UNION | MP 85W-140 |
| VALVOLINE | Gear Lub 85W-140 |

SCHAEFFER 268 Lubricant is available from J&M in five gallon cans. See SECTION VIII ORDERING PARTS.

G. CAPACITIES

| | | |
|---------------------------------|-----|---------|
| 1. Diesel Engine Crankcase | 38 | Quarts |
| 2. Hydraulic System (Reservoir) | 435 | Gallons |
| 3. Vibration Case | 3 | Gallons |
| 4. Fuel Tank Sub-Base (Diesel) | 150 | Gallons |
| 5. Engine Cooling System | 56 | Quarts |
| 6. Multi-Pump Drive Adapter | 8 | Quarts |

IV. MAINTENANCE AND ADJUSTMENTS

H. DRAINING AND FILLING HYDRAULIC FLUID RESERVOIR

1. The Hydraulic reservoir is drained by removing a plug on the bottom of the reservoir.
2. The hydraulic reservoir is filled by the manual pump mounted on the back (engine side) of the reservoir. All fluid is pumped to the reservoir through the return filter (F2) to insure no dirt enters the hydraulic system.

I. CHANGING HYDRAULIC RETURN FILTER ELEMENTS

1. The two return filters are located on the hydraulic reservoir below the Control Panel.
2. To remove the return filter elements, remove the 4 hex head bolts from the housing cover. The bypass valve assembly is bolted to the cover.
NOTE: Approximately 1 gallon (3.8L) of hydraulic oil will be lost.
3. Remove and separate the two elements. Save the plastic element connector; The use of J&M filter elements is strongly recommended. Always use support springs installed inside of the elements. Remove and reuse the support springs from the old elements if new springs are not supplied.
4. Clean filter housing interior and all component parts with a lint free rag.
5. Check cover seal for damage. Lubricate with multi-purpose grease.
6. Install two new elements on filter connector, slide element assembly into housing. Be sure inner most element engages the tube in back of housing.
7. Replace cover with bypass valve assembly.



Failure to install support springs could result in element collapse with subsequent damage to oil cooler and / or filter housing.

8. Repeat for second filter assembly.
9. With new return filter elements installed, start the power unit and run for approximately three minutes. CHECK FOR LEAKS.

IV. MAINTENANCE AND ADJUSTMENTS

J. BOLT TORQUE INFORMATION

Torque, in foot-pounds, is determined by the length of the wrench handle (in feet) multiplied by the weight (or force in pounds) applied at the end of the handle. For example, if the wrench is one foot long and five pounds of force is applied at the end of the handle, the total torque applied would be five foot pounds. A six inch wrench would require ten pounds of force to obtain five foot pounds of torque.

The only way to actually tighten high strength bolts is with proper lubrication and a torque wrench. Proper use of the torque wrench is important. To obtain the listed torques, a steady pull should be exerted to the handle until the desired torque is reached.

The following torque specifications apply to the bolts from the vibrator assemblies listed. Whenever any of these bolts, are installed or replaced, the given torque specifications should be adhered to.

VIBRATION SUPPRESSOR Page VIII-6

| | | |
|-----------------|---------|------------------------|
| Item 17 | 1/2"-13 | 119 Ft-Lbs (16.4 Kg-M) |
| Item 14 | 5/8"-11 | 233 Ft-Lbs (32.3 Kg-M) |
| Item 12, 43, 44 | 3/4"-10 | 417 Ft-Lbs (57.6 Kg-M) |

VIBRATION CASE Page VIII-10

| | | |
|---------|---------|------------------------|
| Item 16 | 1/2"-13 | 119 Ft-Lbs (16.4 Kg-M) |
| Item 17 | 5/8"-11 | 233 Ft-Lbs (32.3 Kg-M) |

CLAMP BODY Page VIII-36

| | | |
|---------|-----------|--------------------------|
| Item 3 | 1"-8 | 1009 Ft-Lbs (139.4 Kg-M) |
| Item 18 | 1 -1/2"-6 | 2800 Ft-Lbs (387 Kg-M) |

**MODEL 44-50
VIBRATORY
DRIVER/EXTRACTOR**

**OPERATING
INSTRUCTIONS**

V. HYDRAULIC CIRCUITRY

A. HYDRAULIC CLAMP

With the diesel engine running, hydraulic fluid is taken from the reservoir by the clamp pump (P2). The clamp pump flow returns to the reservoir if the clamp switch on the pendant has not been moved. Returning oil is filtered by the return filter (F2).

Turning the clamp switch on the control pendant to CLOSE activates the CLAMP CONTROL VALVE (V1). Hydraulic fluid is directed to the CLOSE CLAMP side of the hydraulic CYLINDER (CYL) in the hydraulic clamp. The clamp closes. Clamping pressure is indicated by the clamp pressure gage (GA-3). When clamping pressure reaches approximately 4800 PSI (331 Bar), the CLAMP PRESSURE SWITCH (PS-1) deactivates the CLAMP CONTROL VALVE (V1), which directs the flow from the clamp pump to the reservoir. Pressure at the clamp is maintained by the CLAMP CHECK VALVE (CV5). If clamping pressure falls below 4500 PSI (310 Bar), the CLAMP PRESSURE SWITCH activates the CLAMP CONTROL VALVE to restore pressure. In the event of hose failure, a second CLAMP CHECK VALVE (CV7), located in the CLAMP CYLINDER, will hold the CLAMP CYLINDER closed.

Turning the clamp switch on the control pendant to OPEN activates the CLAMP CONTROL VALVE (V1). Hydraulic fluid is directed to the OPEN CLAMP side of the hydraulic cylinder. The pressure in the OPEN CLAMP line opens the CLAMP CHECK VALVE (CV5). The clamp opens. Pressure in the OPEN CLAMP line is indicated by the clamp pressure gage (GA-4).

Pressure in the clamping circuit is limited to 4800 PSI by the clamp relief valve (RV2). The quick-disconnect couplers (QD3 & QD4) permit de-coupling of the clamp hoses at the power unit.

INFORMATION Clamp pump may also be used to power some auxiliary functions. Contact J&M for information on "POWER BEYOND" modifications.

B. VIBRATOR DRIVE

With the diesel engine running, hydraulic oil is taken from the reservoir by the DRIVE PUMPS (P1). Oil pressure opens the cartridges CA1, CB1 and vents the hydraulic oil back to the reservoir the the RETURN FILTERS (F2), if the vibrator switch is in the OFF position.

Turning the vibrator switch to FORWARD activates the FORWARD SOLENOID on the CONTROL VALVE (V2), directing pump flow to the VIBRATOR MOTOR (M).

V. HYDRAULIC CIRCUITRY

B. VIBRATOR DRIVE (CONTINUED)

Full motor speed is reached within a few seconds and the motor drive pressure is indicated by GAGE (GA1). Maximum drive pressure is limited to approximately 5000 PSI (345 Bar) by the FORWARD RELIEF VALVE (RV1). The FORWARD RELIEF VALVE (RV1), if opened by over pressure, permits a small pilot flow from cartridges (CB1 AND CA2). This pilot flow causes cartridges (CB1 and CA2) to partially open and allows some or all of the pump flow to return to the reservoir. Oil exiting VIBRATOR MOTORS (M) open cartridge BV and returns to the power unit. Cartridge BV opens easily because its pilot flow is “vented” by BRAKE VALVE (RV5). BRAKE VALVE (RV5) is held open by pressure coming from the motor drive FORWARD system. Case drain oil from the motors returns to the reservoir. Case drain pressure is limited to 50 PSI (3.4 Bar) by the CASE DRAIN RELIEF VALVE (RV3). Oil returning to the power unit opens cartridge CB2 and returns to the reservoir through COOLER VALVE (V3), HEAT EXCHANGER (HE) and RETURN FILTERS (F2). Cartridge CB2 opens easily because its pilot flow is “vented” by CONTROL VALVE (V2).

Returning the Vibrator Switch to the center position de-energizes control valve (V2), and again opens cartridges CA1 and CB1 which allows pump flow to return to the reservoir without driving the vibrator. When the Model 580 Power pack is used with the 44-50 Vibrator the RELIEF VALVE (RV4) is set at 4800 PSI. When pressure is removed from the drive FORWARD system, the BRAKE VALVE RELIEF (RV5) closes and blocks the pilot flow BRAKE VALVE (BV) cartridge and causing it to close. Maximum brake pressure generated by BRAKE VALVE (BV) is limited by BRAKE VALVE RELIEF (RV5) to 2000 PSI (138 Bar). This 2000 PSI (138 Bar) back pressure rapidly brakes the motors (M) to a stop.

Hydraulic oil temperature is regulated by the COOLER VALVE (V3). When oil temperature is below 100°F (38°C), V3 directs the flow directly to the reservoir through FILTER (F2). When oil temperature exceeds 100°F (38°C), COOLER VALVE (V3) directs flow through the HEAT EXCHANGER (HE) before it enters the reservoir, through FILTER (F2). Excessive pressure in the HEAT EXCHANGER (HE) is prevented by CHECK VALVE (CV3), which bypasses excess flow and limits pressure to 65 PSI (4.5 Bar).

The quick-disconnect couplers (QD1, QD2, and QD5) permit de-coupling of the drive and case drain hoses at the power unit.

V. HYDRAULIC CIRCUITRY

C. AUGER DRIVE

To convert the 580 Power Unit to operate an J&M, or similar, Bi-Directional Drill re-adjust RELIEF VALVES (RV-1 & RV4) to forward & reverse pressure specified for Auger, and re-set RELIEF VALVE (RV-2), if necessary, for two speed signal.

See J&M Auger Manuals for description of Hydraulic Control Manifold operation, in the "Auger Mode".

D. OTHER

Returning fluid is filtered by the RETURN FILTER (F2). INDICATOR GAGE (GA5) shows condition of FILTER (F2).

A manual PUMP (MP) is provided to fill the hydraulic reservoir. A CHECK VALVE (CV4) prevents loss of fluid from the reservoir back through this pump.

A TEMPERATURE SWITCH (TS) located in the reservoir operates the hydraulic fluid cold light.

The HEAT EXCHANGER (HE) cools the hydraulic fluid returning to the reservoir. The Heat Exchanger is part of the Tripple Core Cooler.

Motor cavitation is prevented in the braking operation by the CHECK VALVE (CV6).

Extra Long ACCUMULATOR HOSE (AC) in pilot system expands as pressure increases. The additional pilot flow causes (CA2) to produce a smooth acceleration of VIBRATOR MOTOR (M).

**MODEL 44-50
VIBRATORY
DRIVER/EXTRACTOR**

**OPERATING
INSTRUCTIONS**

V. HYDRAULIC CIRCUITRY

HYDRAULIC SCHEMATIC

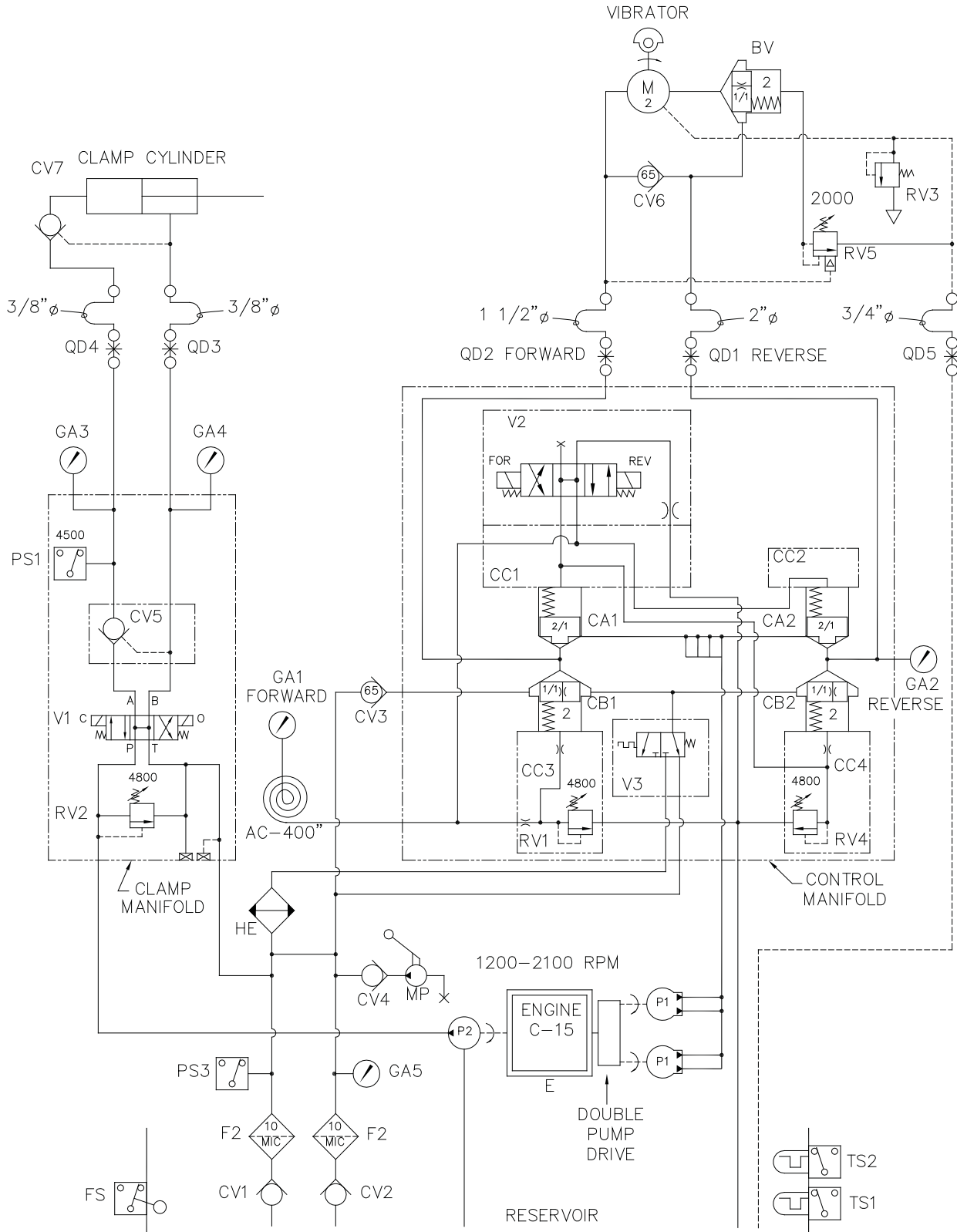

**MODEL 44-50
VIBRATORY
DRIVER/EXTRACTOR**

**OPERATING
INSTRUCTIONS**

V. HYDRAULIC CIRCUITRY

E. HYDRAULIC COMPONENTS LIST

| Notation | Description | Part Number | Page Number |
|----------|------------------------------|-------------|-------------|
| AC | Accumulator Hose | 110680 | VIII-28 |
| BV | Brake Valve | 110150 | VIII-13 |
| CA1 & 2 | Cartridge A (2) | 110624 | VIII-13 |
| CB1 & 2 | Cartridge B (2) | 110622 | VIII-33 |
| CC1 | Cartridge Cover | 110262 | VIII-33 |
| CC2 | Cartridge Cover | 110546 | VIII-33 |
| CC3 | Cartridge Cover | 110606 | VIII-33 |
| CC4 | Cartridge Cover | 110544 | VIII-33 |
| CV1 & 2 | Check Valve Return Filter | 110864 | VIII-31 |
| CV3 | Check Valve - Bypass | 130339 | VIII-33 |
| CV4 | Manual Pump Check Valve | 100451 | VIII-27 |
| CV5 | Clamp Check Valve | 110149 | VIII-35 |
| CV6 | Check Valve - Vibrator | 110296 | VIII-13 |
| CV7 | Check Valve - Clamp Cylinder | 120629 | VIII-37 |
| CYL | Hydraulic Clamp Cylinder | | |
| E | Diesel Engine | 170946 | VIII-26 |
| F2 | Return Filter | 110118 | VIII-28 |
| FS | Float Switch | 100314 | VIII-28 |
| GA1-4 | Pressure Gage | 110600 | VIII-21 |
| GA-5 | Filter Indicator Gage | 100436 | VIII-28 |
| HE | Triple Core Cooler | 100102 | VIII-26 |
| M | Motor | 110328 | VIII-11 |
| MP | Manual Pump | 100447 | VIII-27 |
| P1 | Drive Pump (2) | 110490 | VIII-26 |
| P2 | Clamp Pump | 110401 | VIII-26 |
| PS-1 | Clamp Pressure Switch | 810425 | VIII-35 |
| PS3 | Pressure Switch | 100602 | VIII-29 |
| QD1 | Vibrator Reverse Disconnect | 110690 | VIII-31 |
| QD2 | Vibrator Forward Disconnect | 110692 | VIII-31 |
| QD3 | Clamp Open Disconnect | 100777 | VIII-27 |
| QD4 | Clamp Close Disconnect | 100245 | VIII-27 |
| QD5 | Case Drain Disconnect | 400095 | VIII-27 |
| RV1 | Forward Relief Valve | 100632 | VIII-33 |
| RV2 | Clamp Relief Valve | 100898 | VIII-35 |
| RV3 | Case Drain Relief Valve | 100032 | VIII-13 |
| RV4 | Reverse Relief Valve | 100632 | VIII-33 |
| RV5 | Brake Valve Relief | 110242 | VIII-13 |
| TS1 | Temperature Switch | 110590 | VIII-29 |
| TS2 | Temperature Switch | 110640 | VIII-21 |
| VI | Clamp Control Valve | 120899 | VIII-35 |
| V2 | Control Valve | 120899 | VIII-33 |
| V3 | Cooler Valve | 110628 | VIII-33 |

**MODEL 44-50
VIBRATORY
DRIVER/EXTRACTOR**

**OPERATING
INSTRUCTIONS**



**MODEL 44-50
VIBRATORY
DRIVER/EXTRACTOR**

**OPERATING
INSTRUCTIONS**

VI. ELECTRIC CIRCUITRY (REFERENCE:ELECTRICAL SCHEMATIC PG VI-6)

A. STARTING DIESEL ENGINE

The BATTERIES (EB1, EB2) provides 24-volt current to start the diesel engine. With the MAIN POWER switch ON (the vibrator switch REV-FOR on the remote control pendant should be in the OFF position) and hold the SHUTDOWN RESET button in, turning the ENGINE START SWITCH to START energizes the START RELAY which energizes the STARTER MOTOR and turns over the diesel engine. If fuel is available, the diesel engine will start. The HOUR METER indicates engine operating hours. A TACHOMETER indicates engine speed.

B. STOPPING DIESEL ENGINE

Turning the ENGINE START switch to OFF de-energizes the switched power to the ECM which shuts off the fuel supply to the diesel engine. The engine stops.



MODEL 44-50
VIBRATORY
DRIVER/EXTRACTOR

OPERATING INSTRUCTIONS

VI. ELECTRICAL CIRCUITRY

C. SAFETY CONTROL SYSTEM

INFORMATION

A system of safety controls shut off the fuel supply, which stops the diesel engine in the event that engine water temperature is too high or engine oil pressure is too low.

The heart of the safety system is the shutdown reset, which is normally closed, thereby providing current to operate the HOUR METER and to energize the FUEL SOLENOID. Energizing the fuel solenoid opens the injector pump and allows fuel to flow to the diesel engine. The shutdown reset must remain closed so that fuel continues to flow to the diesel engine.

If the coil in the shutdown reset is energized, the shutdown reset will open, shutting off the fuel to the diesel engine. The engine will stop. The coil may be energized by either of the following devices:

1. ENGINE OIL PRESSURE GAGE - If oil pressure is below 15 PSI, contacts in the gage will be closed providing current to energize the shutdown reset coil. On start-up, the reset button of the shutdown reset (on the control panel) must be held in until oil pressure exceeds 30 PSI.
2. ENGINE WATER TEMPERATURE GAGE - If water temperature exceeds 210°F(99°C), the contacts of the gage will close energizing the shutdown reset coil.
3. Pushing the EMERGENCY STOP BUTTON on Control Pendant energizes the shutdown reset coil.
4. Return Filter Switch - if the hydraulic return filter is clogged, the return filter switch (PS3) will close energizing the shutdown reset and turning on the indicator light. The Return Filter Shutdown is disabled if the Temperature Switch Contacts (TS1) are opened by oil temperature less than 100°F(38°C).
5. Hydraulic Level Float Switch - If the hydraulic fluid level drops below the float switch (about 30 gallons), the contacts of the switch will close energizing the shutdown reset coil. This also will turn on the HYDRAULIC FLUID LEVEL LOW light.
6. Hydraulic Oil temperature Gage -if the temperature of the hydraulic oil exceeds 160°F(71°C), the hydraulic oil temperature gage switch will close, energizing the shutdown reset coil. This will also turn on the indicator light.



**MODEL 44-50
VIBRATORY
DRIVER/EXTRACTOR**

**OPERATING
INSTRUCTIONS**

VI. ELECTRICAL CIRCUITRY

D. CLOSING HYDRAULIC CLAMP

With the diesel engine running, turning the clamp switch (OPEN-CLOSE), on the control pendant to CLOSE energizes the close-clamp solenoid (CLOSE-SOL.). This operates the clamp control hydraulic valve and closes the clamp.

When the pressure in the close-clamp hydraulic circuit reaches 4800 PSI, the pressure switch (PS-1) opens and de-energizes the close-clamp solenoid and turns on the CLAMP LIGHTS on the control pendant and control panel. If close-clamp pressure falls below 4500 PSI, the pressure switch closes and re-energizes the close-clamp solenoid to rebuild pressure. The CLAMP LIGHTS go out. When pressure returns to 4800 PSI, The pressure switch opens de-energizing the close-clamp solenoid and turns on the CLAMP LIGHTS.

E. OPENING HYDRAULIC CLAMP

With the diesel engine running, turning the clamp switch (OPEN-CLOSE) to OPEN energizes the open-clamp solenoid (OPEN SOL.). The clamp opens.

F. STARTING VIBRATOR

With the diesel engine running, turning the vibrator switch on the control pendant to the FORWARD position energizes the forward SOLENOID on the control valve(V2). The control valve directs hydraulic fluid to the hydraulic motors and the vibrator starts.

G. STOPPING VIBRATOR

With the diesel engine running, turning the vibrator switch on the control pendant to the center position de-energizes the forward SOLENOID. Fluid no longer is directed to the motors and they stop.



MODEL 44-50
VIBRATORY
DRIVER/EXTRACTOR

OPERATING INSTRUCTIONS

VI. ELECTRICAL CIRCUITRY

H. OTHER

The ammeter (AM) indicates charging amperes. The tachometer generator (TACH GEN) powers the tachometer (TACH) to indicate engine speed. The Hour meter(M1) indicates the engine operating hours. The hydraulic fluid cold light indicates fluid temperature is below 70°F (21°C), this is sensed by the temp. switch (T.S.) located on front of reservoir. Pushing the button tests the bulb and power to complete circuit.

Duplicate vibrator and clamp switches are located on the control pendant and on the control panel. Turning the LOCAL-PENDANT switch to LOCAL activates only the clamp and vibrator switches located on the control panel. Turning the LOCAL-PENDANT switch to PENDANT only permits operation of the clamp and vibrator from the control pendant. The EMERGENCY STOP button on the control pendant is functional at all times.

Turning the Governor switch to the FAST position will increase engine speed (RPM). Turning the Governor switch to the SLOW position will decrease engine speed.



MODEL 44-50 VIBRATORY DRIVER/EXTRACTOR

OPERATING INSTRUCTIONS

VI. ELECTRICAL CIRCUITRY

ELECTRICAL LAYOUT

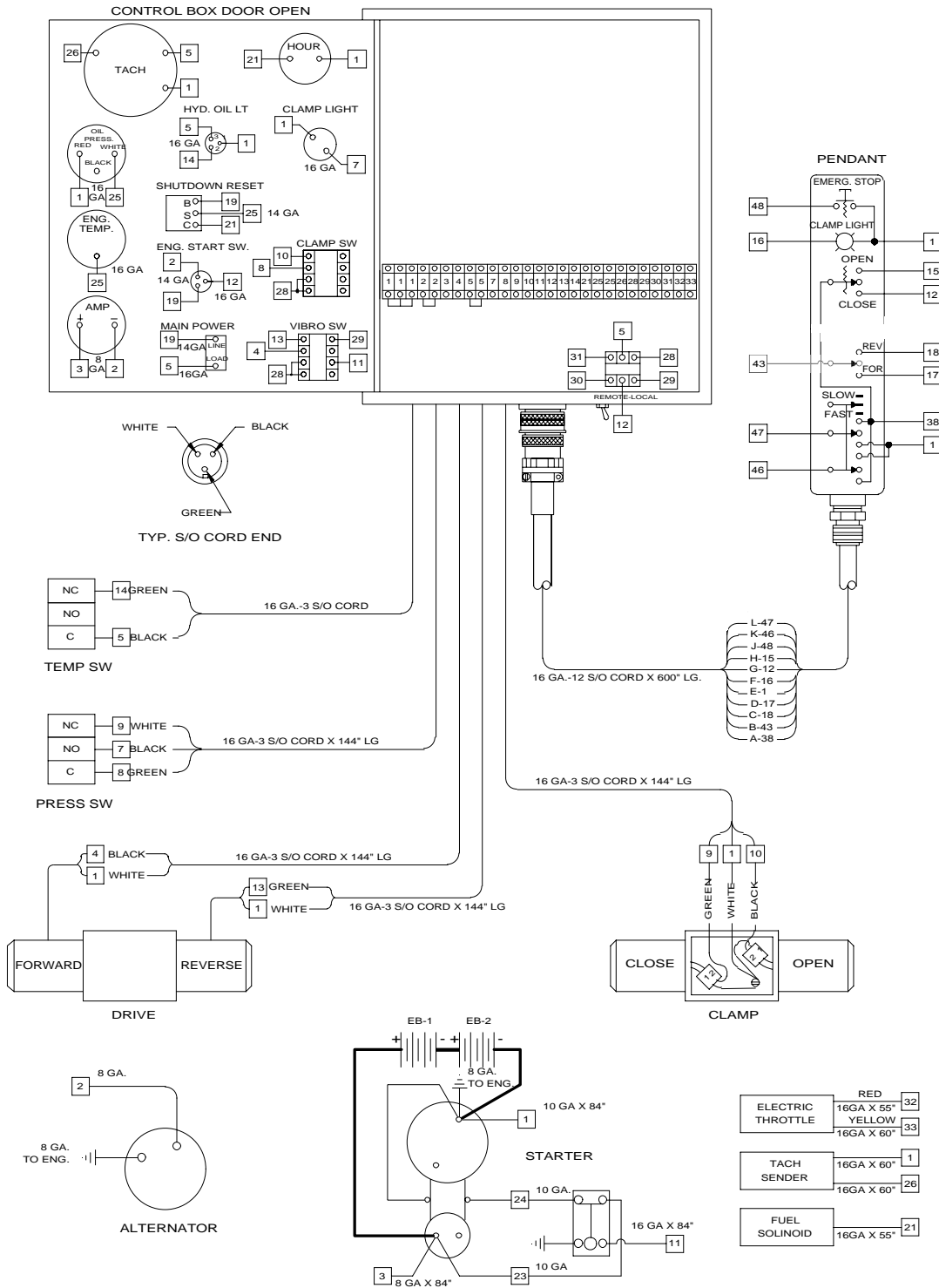



MODEL 44-50 VIBRATORY DRIVER/EXTRACTOR

OPERATING INSTRUCTIONS

VI. ELECTRICAL CIRCUITRY

ELECTRICAL SCHEMATIC

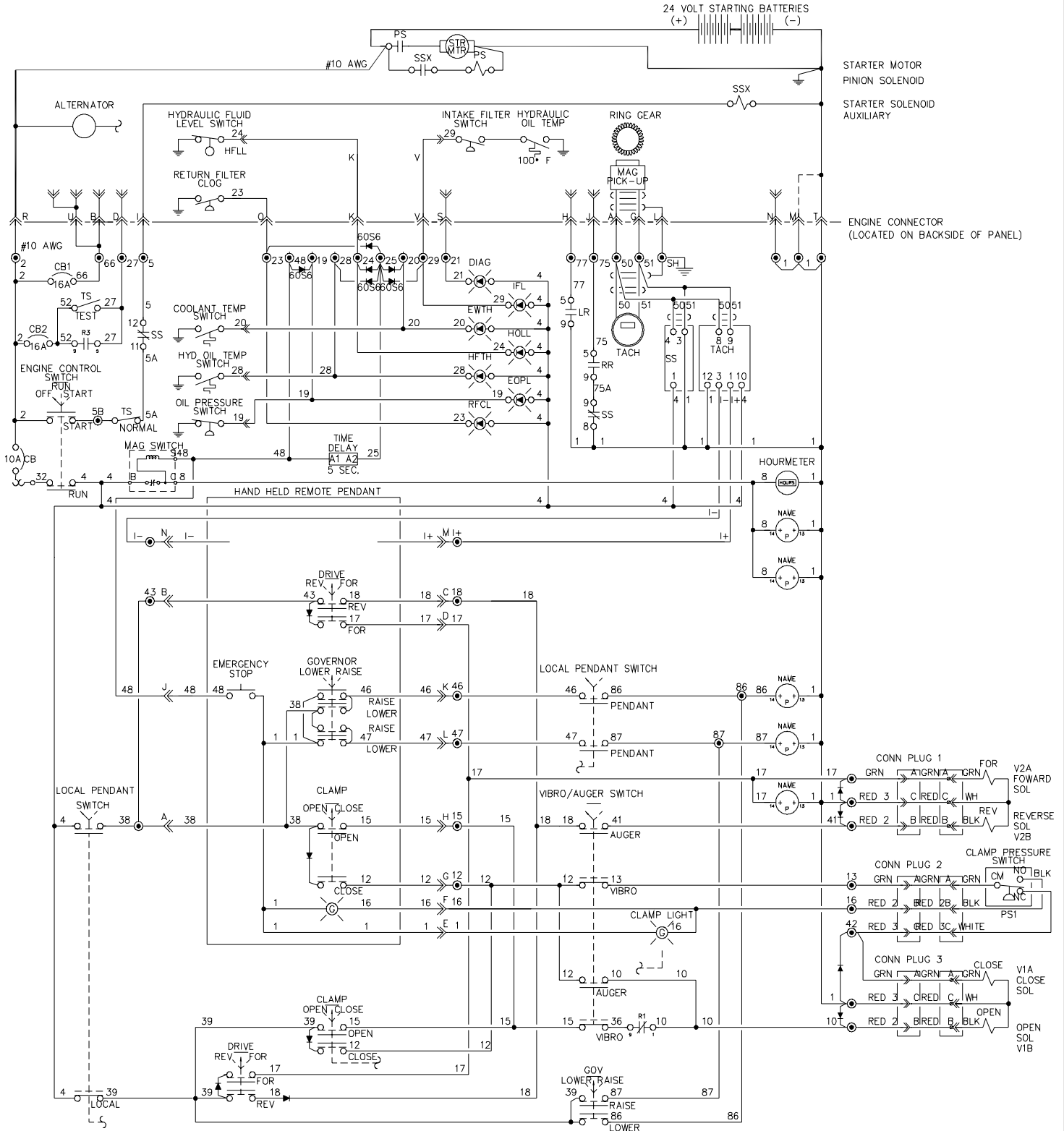



MODEL 44-50
VIBRATORY
DRIVER/EXTRACTOR

OPERATING INSTRUCTIONS

VI. ELECTRICAL CIRCUITRY

I. ELECTRICAL COMPONENTS LIST

| <u>Notation</u> | <u>Reference</u> | <u>Part Number</u> | <u>Page Number</u> |
|------------------|--|------------------------|------------------------|
| ALTERNATOR | Alternator | See Cat. Parts Book | |
| AMMETER | Ammeter | 110371 | VIII-19 |
| BATTERY | 24-Volt Battery | 150081 | VIII-27 |
| CB | Main Power Circuit Breaker | 400141 | VIII-19 |
| CB1, CB2 | Circuit Breaker 16 Amp | 170871 | VIII-21 |
| CLAMP LIGHT (2) | Clamp Light Bulb | 130305 | VIII-19 |
| DRIVE (2) | Vibrator Switch (FWD/REV) | 170841 | VIII-19 |
| EMERG STOP | Emergency Stop Button | 130507 | VIII-23 |
| ENG. OIL PRESS. | Engine Pressure Gage and Switch | 100329 | VIII-19 |
| ENG. START SW. | Engine Start Switch | 110615 | VIII-19 |
| ENG. WATER TEMP. | Engine Water Temperature Gage and Switch | 110697 | VIII-19 |
| HOUR METER | Hour Meter | 100343 | VIII-19 |
| HYD. FLUID TEMP | Hyd.Fluid Temperature Switch Gage | 110640 | VIII-21 |
| L1-L6 | Shutdown Indicator Light | 170875 | VIII-19 |
| L7 | Diagnostic Indicator Light | 170956 | VIII-21 |
| LOCAL-REMOTE | Local-Remote Switch | 170843 | VIII-19 |
| LOWER-RAISE | Engine Throttle Switch | 100566 | VIII-19 |
| LR | Engine Governor Decrease | 170887 | VIII-21 |
| MAG SWITCH | Shutdown Reset | 130257 | VIII-19 |
| OPEN/CLOSE (2) | Clamp Switch (OPEN/CLOSE) | 170837 | VIII-19 |
| PS-1 | Pressure Switch | 810425 | VIII-35 |
| RR | Engine Governor Increase | 170887 | VIII-21 |
| STR MTR | Engine Starter Motor | See Cat.Parts Book | |
| TACH | Tachometer | 170905 | VIII-19 |
| V1A | Close-Clamp Solenoid (Valve) | 110147 | VIII-35 |
| V1B | Open-Clamp Solenoid (Valve) | 110147 | VIII-35 |
| V2A | Forward Solenoid (Valve) | 110147 | VIII-33 |
| V2B | Reverse Solenoid (Valve) | 110147 | VIII-33 |



MODEL 44-50
VIBRATORY
DRIVER/EXTRACTOR

OPERATING INSTRUCTIONS



**MODEL 44-50
VIBRATORY
DRIVER/EXTRACTOR**

PARTS LIST

VII. GENERAL DATA

A. ABBREVIATIONS

The abbreviations shown below are used throughout the parts lists and various other parts of the manual.

| | |
|------|-----------------------------|
| ASM. | Assembly |
| BHCS | Button Head Cap Screw |
| Cyl. | Cylinder |
| DC | Direct Current |
| FHCS | Flat Head Cap Screw |
| FLCS | Flanged Head Cap Screw |
| HC | High Collar |
| HHCS | Hex Head Cap Screw |
| HHPP | Hex Head Pipe Plug |
| HSSS | Hex Socket Set Screw |
| Hyd. | Hydraulic |
| Lg. | Long |
| mm | Millimeter |
| Mtg. | Mounting |
| NPT. | National Pipe Thread |
| PHMS | Phillips Head Machine Screw |
| P/N | Part Number |
| Qty. | Quantity |
| RHMS | Round Head Machine Screw |
| Sch. | Schedule |
| SHCS | Socket Head Cap Screw |
| SHPP | Socket Head Pipe Plug |
| SHSS | Socket Head Shoulder Screw |
| S/N | Serial Number |
| Sol. | Solenoid |

B. SCREWS AND BOLTS

1. Practically all connections on the unit are made with socket head (Allen) cap screws. These high-strength screws are available at most industrial supply houses.
2. Screws and bolts are designated in the PARTS LIST in abbreviated form. (Refer to sub-section A, above, for specific abbreviations.) Listed below is a typical screw description: 0.50 - 13 UNC X 1.50 LG SHCS

0.50 = Diameter 13 UNC = Threads Per Inch
1.50 LG = Length SHCS = Screw Type Abbreviation

3. Some screws or bolts require a specific torque when replacing. For identification of these bolts and a more thorough understanding of torque, refer to Page IV-9.



MODEL 44-50
VIBRATORY
DRIVER/EXTRACTOR

PARTS LIST

VII. GENERAL DATA

C. SERIAL NUMBER LOCATIONS

1. The following J&M vibratory units are serial numbered separately:
 - a. Vibrator
 - b. Power unit
 - c. Piling Clamps
 - d. Caisson beams
 - e. 90 deg. clamp adapter
2. In addition to the serial number plate itself (on vibrators, power units and clamps), the serial number is stamped into each unit in one or more places as follows:
 - a. Vibrator stamped twice - once on top right side of suppressor housing, once on bottom lip of vibration case on right side of motors' side.
 - b. Power unit stamped twice - once on control panel side of unit at right corner of reservoir, once on sub-base inside door below hex-key rack.
 - c. Model 126 universal clamp is stamped three times - once between cylinder and pile guide, once above the grease fitting, and once on the flange of the cylinder housing.
 - d. Model 127Z-Pile clamp is stamped three times once on top of each cylinder, and once above the grease fitting.
 - e. Model 80 caisson clamp stamped twice - once by the lifting eye, once by the adjusting screw.
 - f. Caisson beam is stamped three times- once on top center, once in center of both sides of flange.
 - g. 90 deg. clamp plate stamped twice - once on top center, once on side.



**MODEL 44-50
VIBRATORY
DRIVER/EXTRACTOR**

PARTS LIST

VIII. ORDERING PARTS

A. PROCEDURE

1. When ordering parts, **be sure to include the model and serial number** of the unit or component. The serial number may be located by referring to SECTION VII, SERIAL NUMBER LOCATION. Confirm all telephone orders immediately to avoid duplicating shipment.
2. ORIGINAL EQUIPMENT; Where component serial numbers are given, these apply only to equipment and components originally furnished with the unit. Where equipment has been changed or upgraded these numbers may not be an adequate description.
3. SHIPMENT; State to whom shipment is to be made and method of shipment desired, otherwise our own judgement will be used.
4. SHORTAGES; Claims for shortages or errors should be made immediately upon receipt of parts. No responsibility will be assumed for delay, damage or loss of material while in transit. Broken, damaged or lost material should be refused or a full description made of damage or loss to the carrier agent on the freight or express bill.
5. RETURN OF PARTS; If for any reason you desire to return parts to the factory or to any distributor from whom these parts were obtained, you must first secure permission to return the parts. Shipping instructions will be given along with this permission. A ten percent handling charge must be assessed against the returned shipment unless an error is made by the factory or by the distributor when filling your order.



**MODEL 44-50
VIBRATORY
DRIVER/EXTRACTOR**

PARTS LIST

VIII. ORDERING PARTS

B. FITTING DESCRIPTION KEY

FITT 2 L - 16 M 12 J 00 0 - 00L 0 0 0 1

SELECTOR INDEX

- 2 - INCH FITTING
- 9 - METRIC FITTING

CONFIGURATION OR
SHAPE OF FITTING

- S - STRAIGHT FITTING
 - L - 90 Deg. ELBOW
 - V - 45 Deg. ELBOW
 - T - TEE
 - C - CAP
 - P - PLUG
 - U - UNION
 - X - CROSS
- (FOURTH END FITTING REQ'D.)

FIRST END SIZE

- * IN 1/16THS OF AN INCH
(INDEX 2)
- IN MILLIMETERS (INDEX 9)
- SEE GENERAL SPECIFICATION
SHEET FOR SEQUENCE OF ORDER

FIRST END FITTING STYLE

- SEE FITTING STYLE SELECTOR
CHART SC-1

SECOND END SIZE

- IF APPLICABLE - SEE
FIRST END SIZE

SECOND END FITTING STYLE

- IF APPLICABLE - SEE
FIRST END FITTING STYLE

THIRD END SIZE

- IF APPLICABLE - SEE
FIRST END SIZE

THIRD END FITTING STYLE

- IF APPLICABLE - SEE
FIRST END SIZE

* EXCEPTIONS

- 90 = 10" 96 = 6"
- 92 = 12" 98 = 8"
- 94 = 14" 99 = NON CODE SIZE

MATERIAL

- 1 - CARBON STEEL
- 2 - BRASS
- 4 - STAINLESS STL
- 5 - AAR MAL IRON
- 6 - MALEABLE IRON
- 8 - FORGED STEEL

SPECIAL NOTATIONS

PRESSURE RATING

- 0 - NONE
- 1 - 125 LB.
- 3 - SCH 40
- 4 - SCH 80

INSTALLATION AID OR
STYLE OF HEAD

- 0 - NOT APPLICABLE
- H - REGULAR HEX
- Q - SQUARE HEAD (EXT.)
- R - SQUARE HEAD (INT.)
- S - HEX HEAD (INT SOCKET)
- T - HEX HEAD (EXT.)

LENGTH CODE

- (ELBOWS & NIPPLES)
- L - LONG (ELBOW)
 - X - EXTRA LONG (ELBOW)
 - C - CLOSE (NIPPLE)

- PIPE NIPPLES (LONG) ONLY
IN DEC. INCHES FOR INDEX 2
- 050 = 5.0 INCHES
 - 105 = 10.5 INCHES

- IN MILLIMETERS FOR INDEX 9
- 120 = 12.0 MILLIMETERS
 - 084 = 8.4 MILLIMETERS

FOURTH END SIZE &
FITTING STYLE

- (CROSSES ONLY)
SEE FIRST END FITTING SIZE OR
END STYLE



**MODEL 44-50
VIBRATORY
DRIVER/EXTRACTOR**

PARTS LIST



B. FITTING DESCRIPTION KEY (CONTINUED)

FITTING STYLE SELECTOR CHART

SC-1

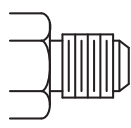
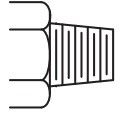
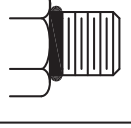
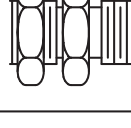
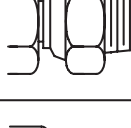
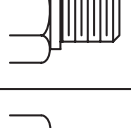
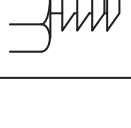
FOR END FITTING STYLE SELECTION

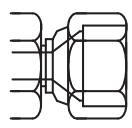
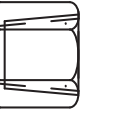
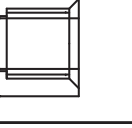
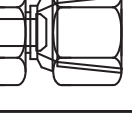
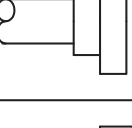
| | | |
|---|---|---|
| M |  | JIC MALE 37 Deg. FLARE |
| P |  | MALE PIPE NPT |
| R |  | S.A.E. MALE O-RING (& ADJUSTABLE) |
| B |  | JIC MALE 37 Deg. FLARE BULKHEAD |
| D |  | MALE PIPE NPT SWIVEL |
| S |  | B.S.P. MALE PIPE |
| T |  | HOSE BARB |

| | | |
|---|---|---|
| J |  | JIC FEMALE 37 Deg. FLARE (& SWIVEL) |
| Q |  | FEMALE PIPE NPTF |
| K |  | S.A.E. FEMALE O-RING |
| N |  | FEMALE PIPE NPSM-SWIVEL |
| F |  | SPLIT FLANGE 3000 PSI. CODE 61 |
| H |  | SPLIT FLANGE 6000 PSI. CODE 62 |

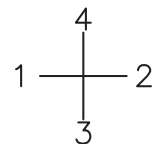



**MODEL 44-50
VIBRATORY
DRIVER/EXTRACTOR**

PARTS LIST

VIII. ORDERING PARTS

C. HOSE DESCRIPTION CODE

The HOSE DESCRIPTION CODE is a 24 digit number enabling easier and quicker identification whenever a hose replacement is desired. The key below explains the structure of the coded number in detail.

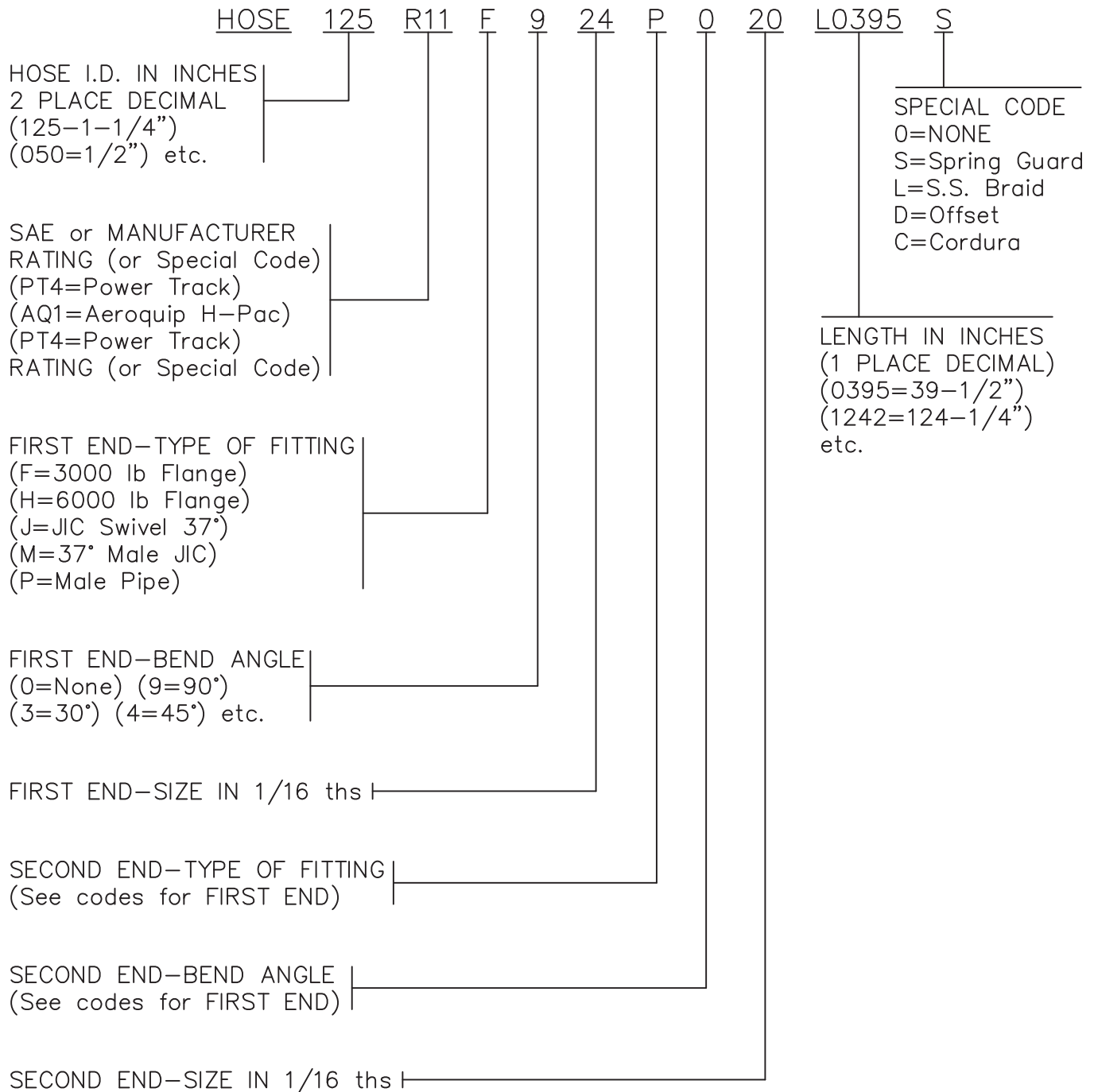



**MODEL 44-50
VIBRATORY
DRIVER/EXTRACTOR**

PARTS LIST

VIII. ORDERING PARTS

D. PARTS IDENTIFICATION

1. Parts lists and drawings are included on the following pages for the equipment components shown below:

| | |
|--------------------------------------|--------|
| a. VIBRATION SUPPRESSOR | 800427 |
| b. VIBRATION CASE | 810649 |
| c. HOSE ASSEMBLIES - INTERCONNECTING | 800053 |
| d. POWER UNIT - ENCLOSURE | 810919 |
| e. CONTROL BOX | 810917 |
| f. CONTROL PENDANT | 800591 |
| g. POWER UNIT - INTERNAL | 800595 |
| h. CONTROL MANIFOLD | 810447 |
| i. CLAMP MANIFOLD | 810915 |
| j. MODEL 126 CLAMP | 800327 |
| k. MODEL 127 Z-PILE CLAMP | 800041 |
| l. MULTI-GRIP JAW SET - 13" | 800417 |
| m. MULTI-GRIP JAW SET - 12" | 800419 |
| n. CLAMP EXTENSION - 10 FOOT | 800423 |
| o. 90 deg. CLAMP ADAPTER | 800049 |
| p. CAISSON BEAM - 7 FOOT | 800477 |
| q. CAISSON BEAM - 11' | 800479 |
| r. MODEL 80 CAISSON CLAMP | 800047 |
| s. MODEL 80 W. LOCK BODY | 800413 |
| t. LOCK BODY | 800399 |
| u. PENDANT EXTENSION-50' | 800059 |
| v. BIAS WEIGHT | 800429 |

2. The spare parts list SECTION VIII - RECOMMENDED SPARE PARTS contains spare parts which may be very useful in keeping down-time to a minimum, especially in remote or secluded job sites where unforeseen communication problems could cause delay of the delivery of an awaited part.

These RECOMMENDED SPARE PARTS may be ordered beforehand, individually or as a package group as shown in the PARTS LIST.



MODEL 44-50
VIBRATORY
DRIVER/EXTRACTOR

PARTS LIST

VIBRATION SUPPRESSOR

800427

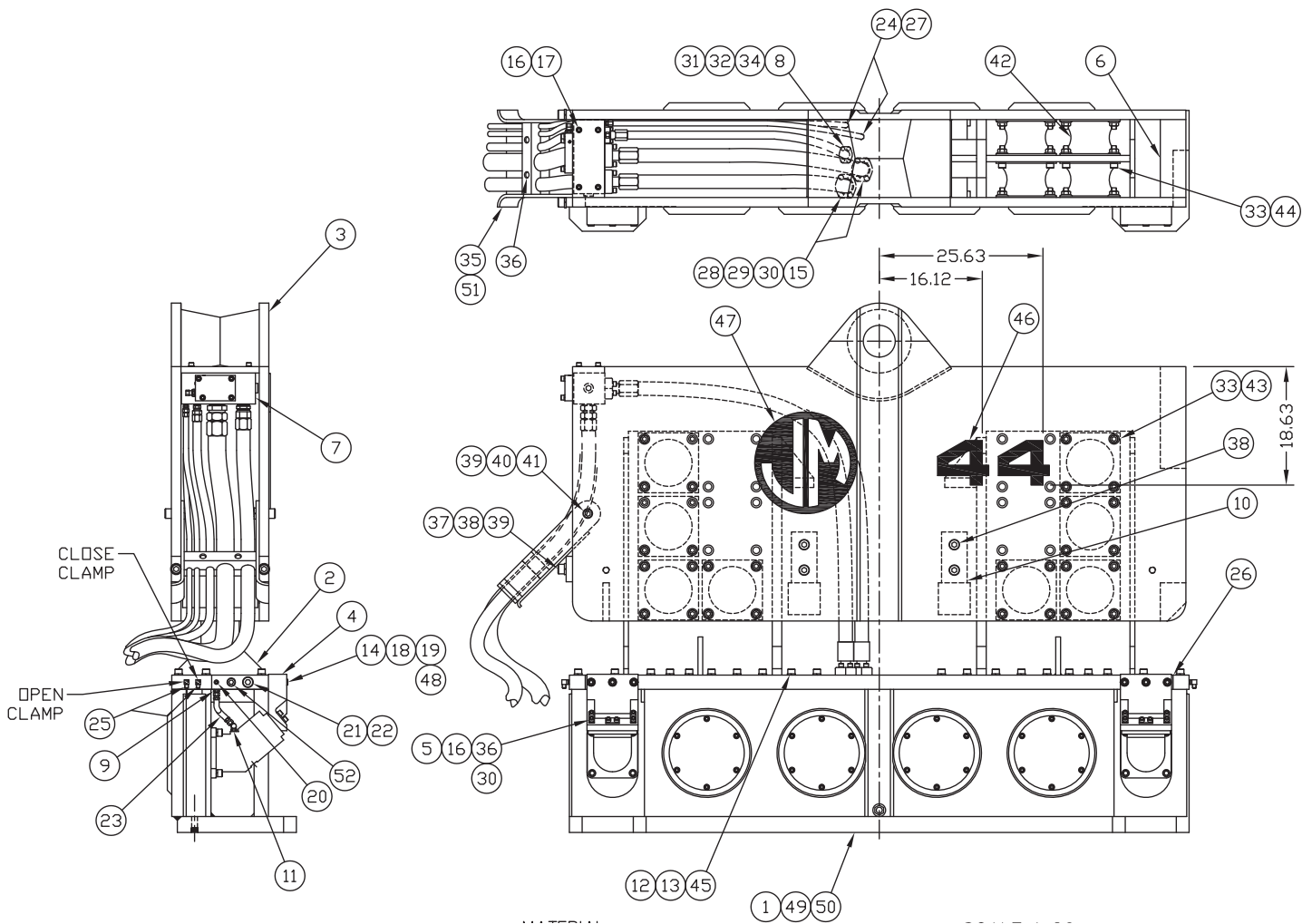



MODEL 44-50
VIBRATORY
DRIVER/EXTRACTOR

PARTS LIST

VIBRATION SUPPRESSOR

800427

| Item | Part Number | Qty. | Description |
|------|-------------|------|-------------------------------|
| 1 | 810649 | 1 | TRANSMISSION ASM |
| 2 | 110362 | 1 | TRANSMISSION ADAPTER |
| 3 | 110360 | 1 | SUPPRESSOR HOUSING |
| 4 | 110364 | 2 | MOTOR MANIFOLD |
| 5 | 110330 | 6 | RETAINER PLATE |
| 6 | 110324 | 1 | S/N PLATE |
| 7 | 810019 | 1 | TERMINAL MANIFOLD ASM |
| 8 | 100051 | 4 | .375-16 X 1.0 LG SHCS LOC WEL |
| 9 | 110630 | 2 | FITT2S-08M06P000-000H001 |
| 10 | 110358 | 2 | STOP BARS |
| 11 | 300099 | 2 | FITT2S-10R08M000-000H001 |
| 12 | 140111 | 44 | .75-10 X 4.0 LG SHCS LW |
| 13 | 100069 | 44 | .75 LOCK WASHER MEDIUM |
| 14 | 130135 | 6 | .63-11UNC X 3.50 LG SHCS |
| 15 | 140907 | 2 | HOSE150PT6F024F024L0835C |
| 16 | 100121 | 16 | .50 LOCK WASHER MEDIUM |
| 17 | 100011 | 4 | .50-13 UNC X 2.00 LG SHCS |
| 18 | 110236 | 6 | .625 FLAT WASHER EXTRA HEAVY |
| 19 | 100007 | 6 | .625 LOCK WASHER MEDIUM |
| 20 | 400213 | 2 | FITT2P-06P000000-000S007 |
| 21 | 100063 | 2 | FITT2P-16P000000-000S007 |
| 22 | 160503 | 2 | FITT2P-20R000000-000S007 |
| 23 | 100486 | 2 | HOSE050R01J008J008L01450 |
| 24 | 400203 | 2 | FITT2S-06M06P000-000H001 |
| 25 | 130921 | 4 | FITT2L-06M08R000-0000001 |
| 26 | 100183 | 2 | FITT2P-12P000000-000S007 |
| 27 | 140905 | 2 | HOSE038R02J006J006L0835C |
| 28 | 100596 | 4 | #24 SPLIT FLANGE HALF |
| 29 | 100119 | 8 | .5-13 X 1.25 LG SHCS LOC WEL |
| 30 | 110119 | 6 | 2-225 O-RING |
| 31 | 100049 | 2 | #12 SPLIT FLANGE HALF |
| 32 | 140903 | 1 | HOSE075PT4F012FO12L0835C |
| 33 | 100782 | 96 | .75-10 FLANGE NUT |
| 34 | 100097 | 1 | 2-214 O-RING 70 DURO |
| 35 | 110356 | 1 | HOSE CHUTE |
| 36 | 400043 | 14 | .5-13 x 2.25LG SHCS |
| 37 | 110354 | 1 | HOSE CHUTE SUPPORT |
| 38 | 100213 | 10 | 1.0-8 X 2.50 LG SHCS LOC WEL |
| 39 | 100209 | 4 | 1.00 LOCK WASHER MEDIUM |
| 40 | 140145 | 2 | 1.0-8 X 3.5 LG SHCS |



MODEL 44-50
VIBRATORY
DRIVER/EXTRACTOR

PARTS LIST



MODEL 44-50
VIBRATORY
DRIVER/EXTRACTOR

PARTS LIST

VIBRATION SUPPRESSOR

800427

| Item | Part Number | Qty. | Description |
|------|-------------|------|-------------------------------|
| 41 | 400051 | 2 | 1.0-8 HEX NUT |
| 42 | 100796 | 16 | ELASTOMER |
| 43 | 400069 | 64 | .75-10 x 2.0 LG SHCS |
| 44 | 100067 | 32 | .75-10 X 2.5 LG SHCS LOC WEL |
| 45 | 170811 | 250 | O-RING CORD 0.125 C.S. / INCH |
| 46 | 110745 | 4 | 4 LOGO |
| 47 | 400278 | 2 | J&M LOGO |
| 48 | 100037 | 4 | 2-222 O-RING 90 DURO |
| 49 | 110248 | 4 | FITT2P-12R000000-0000001 |
| 50 | 110238 | 1 | HOSE CLAMP |
| 51 | 130829 | 2 | FITT2P-16R |
| 52 | | 2 | HOSE CHUTE LABEL |



MODEL 44-50
VIBRATORY
DRIVER/EXTRACTOR

PARTS LIST

VIBRATION CASE

810649

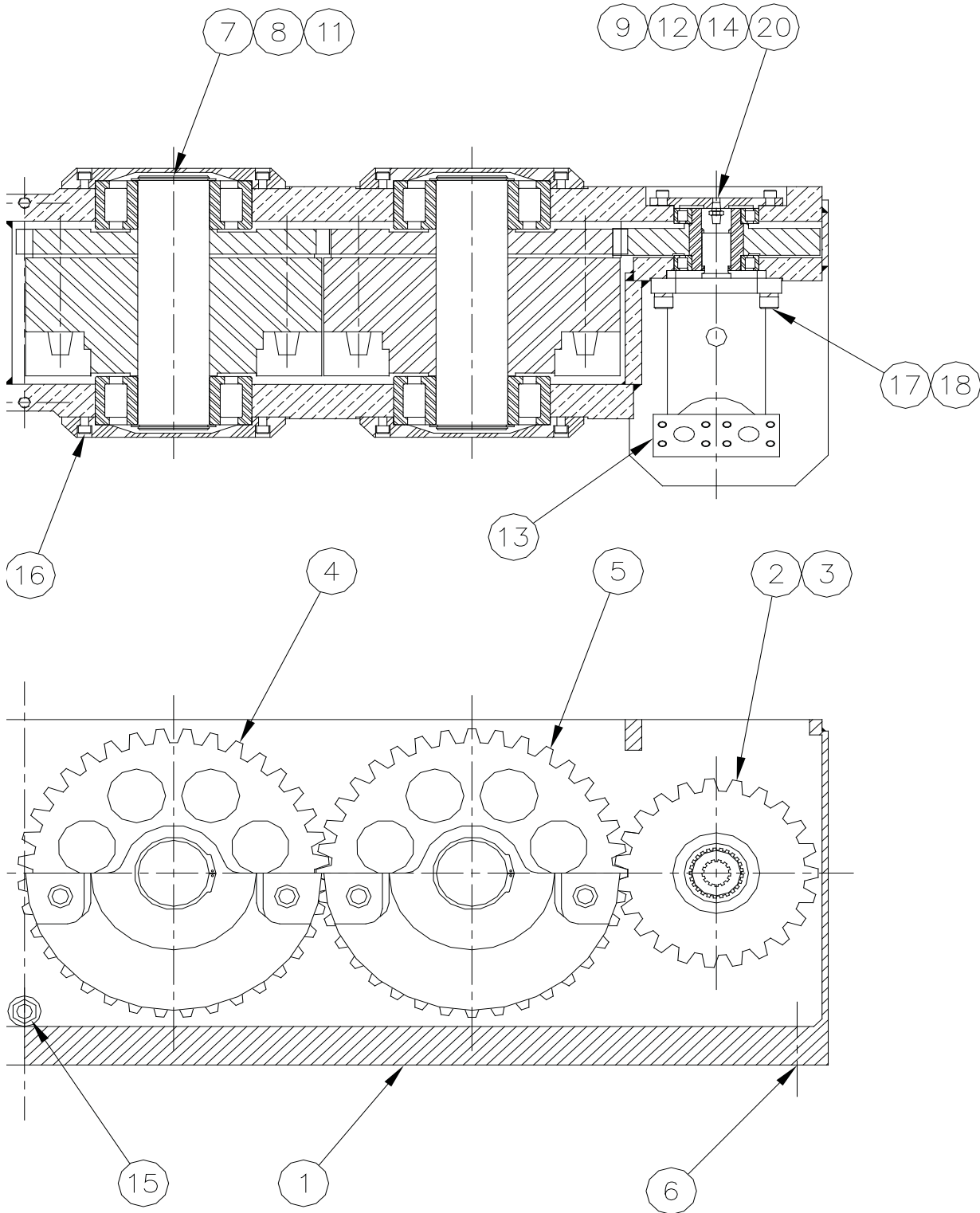



MODEL 44-50
VIBRATORY
DRIVER/EXTRACTOR

PARTS LIST

VIBRATION CASE

810649

| Item | Part Number | Qty. | Description |
|------|-------------|------|-------------------------------|
| 1 | 810647 | 1 | TRANSMISSION CASE FRAME |
| 2 | 110370 | 2 | PINION SHAFT |
| 3 | 110376 | 2 | PINION GEAR |
| 4 | 810673 | 2 | ECCENTRIC GEAR ASM |
| 5 | 810675 | 2 | ECCENTRIC GEAR ASM |
| 6 | 110132 | 3 | FITT2P-16P000000-000S0M7 |
| 7 | 110316 | 8 | RETAINING RING |
| 8 | 110372 | 4 | ECCENTRIC SHAFT |
| 9 | 110366 | 2 | BEARING HOUSING |
| 10 | 110368 | 8 | BEARING COVER |
| 11 | 110314 | 8 | ECCENTRIC BEARING |
| 12 | 110312 | 4 | MOTOR BEARING |
| 13 | 110328 | 2 | 44-50 DRIVE MOTOR |
| 14 | 810229 | 2 | BREATHER ASM |
| 15 | 100185 | 1 | SIGHT GAUGE |
| 16 | 100119 | 56 | .5-13 X 1.25 LG SHCS LOC WEL |
| 17 | 400069 | 8 | .75-10 X 2.00 LG SHCS LOC WEL |
| 18 | 400727 | 8 | .75 HI-COLLAR LOCK WASHER |
| 19 | 110444 | 3 | TRANSMISSION OIL / GAL. |
| 20 | 170833 | 2 | 2-161 O-RING |
| 21 | 400053 | 8 | 2-273 O-RING |
| 22 | 110195 | 2 | 2-163 O-RING |



MODEL 44-50
VIBRATORY
DRIVER/EXTRACTOR

PARTS LIST

TERMINAL BLOCK

810019

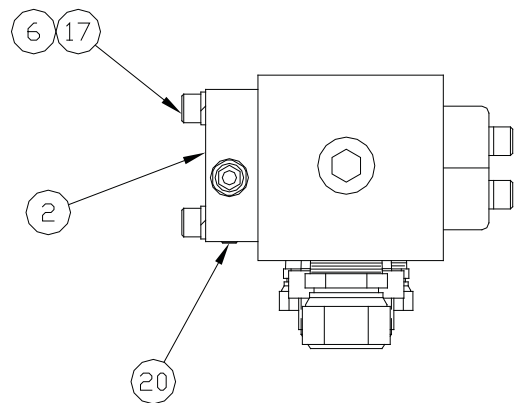
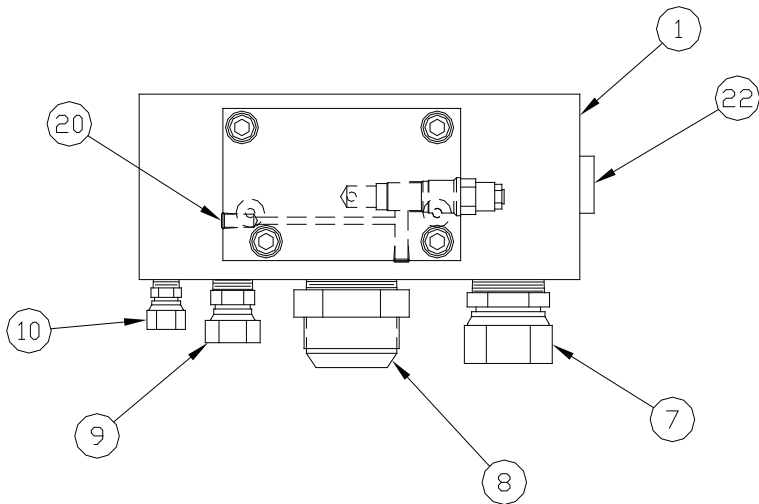
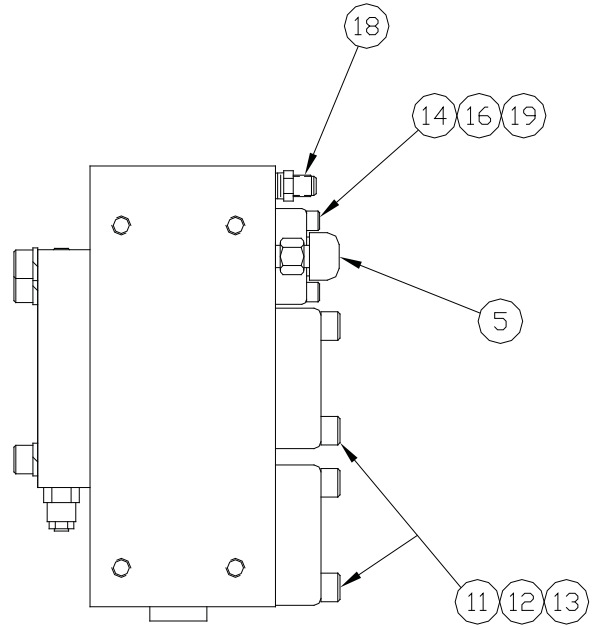
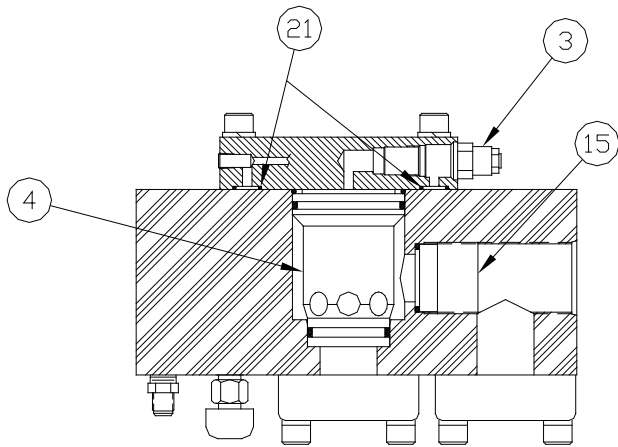



MODEL 44-50
VIBRATORY
DRIVER/EXTRACTOR

PARTS LIST

TERMINAL BLOCK

810019

| Item | Part Number | Qty. | Description |
|------|-------------|------|-------------------------------|
| 1 | 110352 | 1 | TERMINAL MANIFOLD |
| 2 | 110252 | 1 | MANIFOLD CAP |
| 3 | 110242 | 1 | BRAKE VALVE |
| 4 | 110150 | 1 | CARTRIDGE B |
| 5 | 110214 | 1 | RELIEF VALVE |
| 6 | 100121 | 4 | .50 LOCK WASHER MEDIUM |
| 7 | 100565 | 1 | FITT2S-24P24M000-000H001 |
| 8 | 110269 | 1 | FITT2S-24P32M000-000H001 |
| 9 | 140759 | 1 | FITT2S-16M12P000-000H001 |
| 10 | 100041 | 2 | FITT2S-06PO6N000-000H001 |
| 11 | 100596 | 4 | #24 SPLIT FLANGE HALF |
| 12 | 100119 | 8 | .5-13 X 1.25 LG SHCS LOC WEL |
| 13 | 110119 | 2 | 2-225 O-RING |
| 14 | 100049 | 2 | #12 SPLIT FLANGE HALF |
| 15 | 110296 | 1 | CHECK VALVE |
| 16 | 100097 | 1 | 2-214 O-RING 70 DURO |
| 17 | 400043 | 4 | .5-13 x 2.25LG SHCS |
| 18 | 400203 | 2 | FITT2S-06M06P000-000H001 |
| 19 | 100051 | 4 | .375-16 X 1.0 LG SHCS LOC WEL |
| 20 | 100646 | 2 | FITT2P-02P000000-000S007 |
| 21 | 140255 | 2 | 2-113 O-RING 90 DURO |
| 22 | 110298 | 1 | FITT2P-24R000000-000S001 |

Installation tool for It 15 from Inserta Adacon IMT-E-24



**MODEL 44-50
VIBRATORY
DRIVER/EXTRACTOR**

PARTS LIST

HOSE ASSEMBLIES - INTERCONNECTING

800053

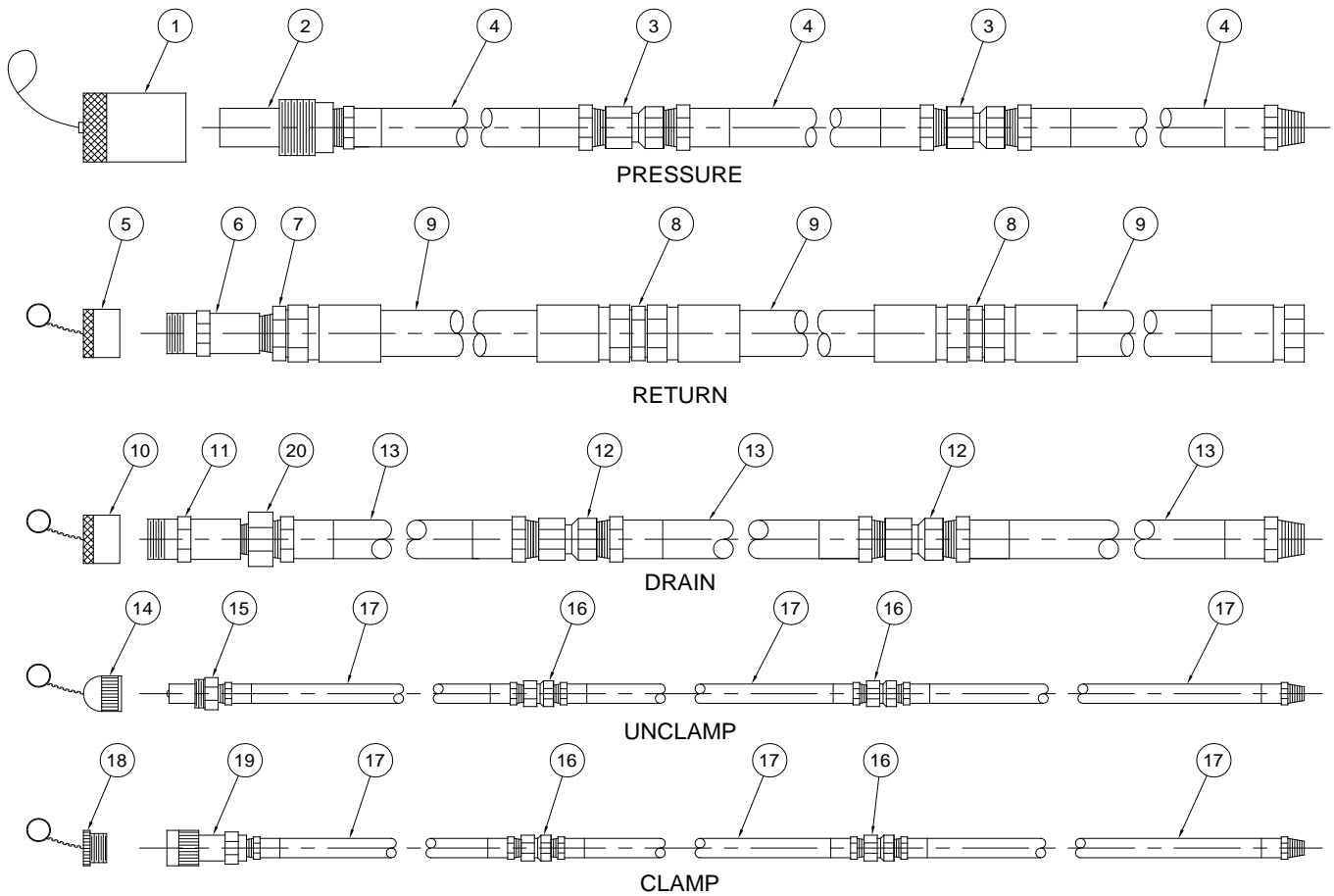



MODEL 44-50
VIBRATORY
DRIVER/EXTRACTOR

PARTS LIST

HOSE ASSEMBLIES

800053

| Item | Part Number | Qty. | Description |
|------|-------------|------|--------------------------|
| 1 | 110955 | 1 | 1.50 DUST CAP |
| 2 | 110690 | 1 | 1.50 MALE DISCONNECT |
| 3 | 100565 | 1 | FITT2S-24P24M000-000H001 |
| 4 | 110240 | 2 | FITT2S-24M24M000-000H001 |
| 5 | 110141 | 3 | HOSE150PT6J024J024L60000 |
| 6 | 110692 | 1 | 1.50 FEMALE DISCONNECT |
| 7 | 110957 | 1 | 1.50 DUST PLUG |
| 8 | 110271 | 2 | FITT2S-32M32M000-000H001 |
| 9 | 110970 | 3 | HOSE200R02J032J032L60000 |
| 10 | 400253 | 1 | .75 DUST CAP |
| 11 | 400251 | 1 | .75 MALE DISCONNECT |
| 12 | 130789 | 3 | FITT2S-16M16M000-000H001 |
| 13 | 140685 | 3 | HOSE100PT4J016J016L62000 |
| 14 | 100257 | 1 | .375 DUST CAP |
| 15 | 100245 | 1 | .375 MALE DISCONNECT |
| 16 | 120081 | 6 | FITT2S-06M06M000-000H001 |
| 17 | 100247 | 6 | HOSE038R02J006J006L60000 |
| 18 | 100737 | 1 | .375 DUST PLUG |
| 19 | 100777 | 1 | .375 FEMALE DISCONNECT |
| 20 | 140759 | 1 | FITT2S-12P16M000-000H001 |
| 21 | 110269 | 1 | FITT2S-32M24P000-000H001 |
| 22 | 400203 | 2 | FITT2S-06M06P000-000H001 |
| 23 | | 1 | HOSE100PT4J016J016L05400 |
| 24 | | 2 | HOSE038R02J006J006L05400 |



MODEL 44-50
VIBRATORY
DRIVER/EXTRACTOR

PARTS LIST

POWER UNIT ENCLOSURE

810919

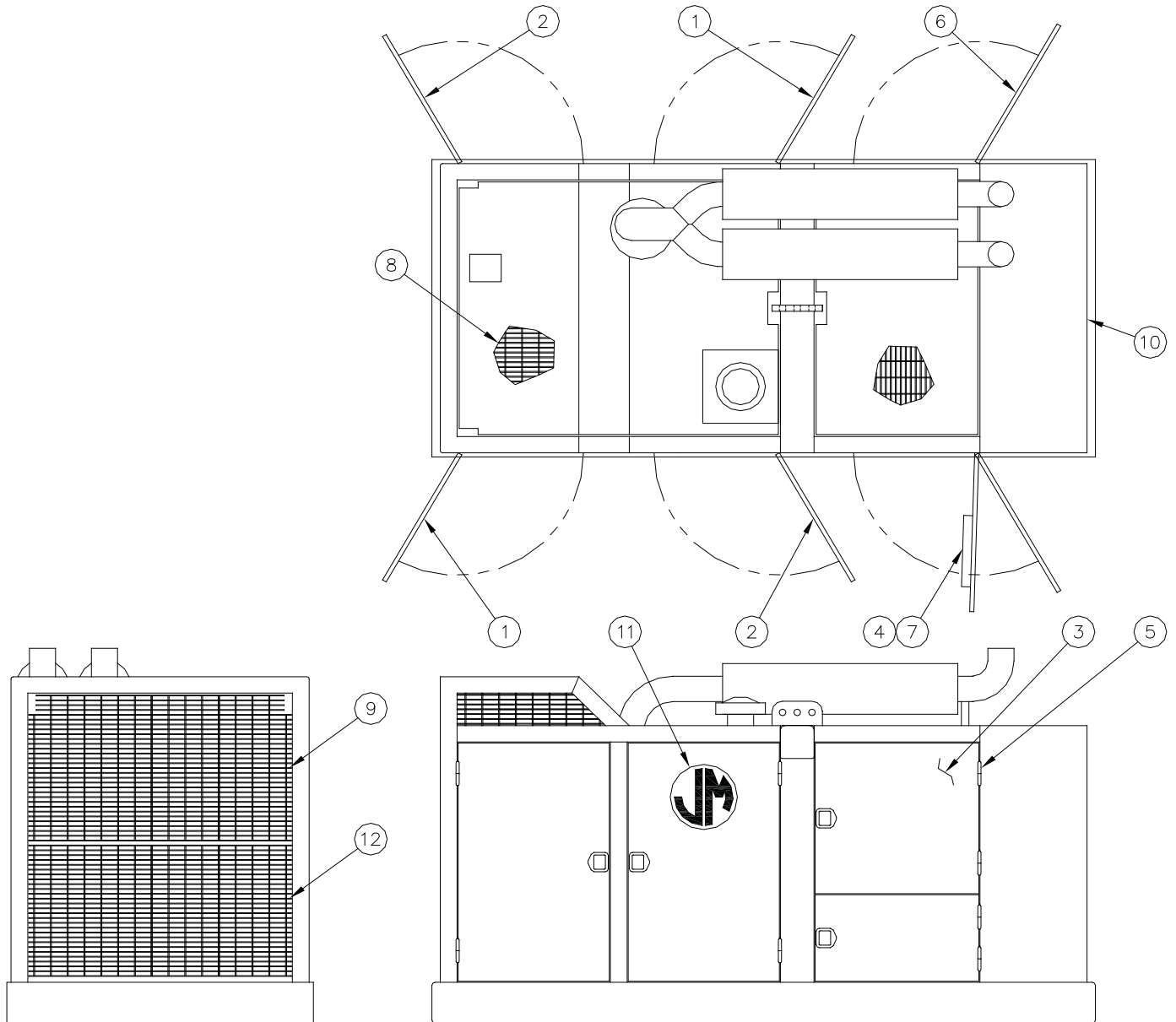



MODEL 44-50
VIBRATORY
DRIVER/EXTRACTOR

PARTS LIST

POWER UNIT ENCLOSURE

810919

| <u>Item</u> | <u>Part Number</u> | <u>Qty.</u> | <u>Description</u> |
|-------------|------------------------|-------------|---------------------------|
| 1 | 610423 | 2 | Cover Door |
| 2 | 610424 | 2 | Cover Door |
| 3 | 610418 | 1 | Cover Door |
| 4 | 610420 | 1 | Cover Door |
| 5 | 100834 | 14 | Bullet Hinge |
| 6 | 610422 | 1 | Cover Door |
| 7 | 100600 | 1 | Hex Key Rack |
| 8 | 610444 | 1 | Exhaust Grill Top Grates |
| 9 | 610442 | 1 | Intake Grill Front Top |
| 10 | 400278 | 1 | J&M Logo Plate |
| 11 | 100290 | 2 | J&M Decal |
| 12 | 610450 | 1 | Intake Grill Front Bottom |



**MODEL 44-50
VIBRATORY
DRIVER/EXTRACTOR**

PARTS LIST

CONTROL BOX

810917

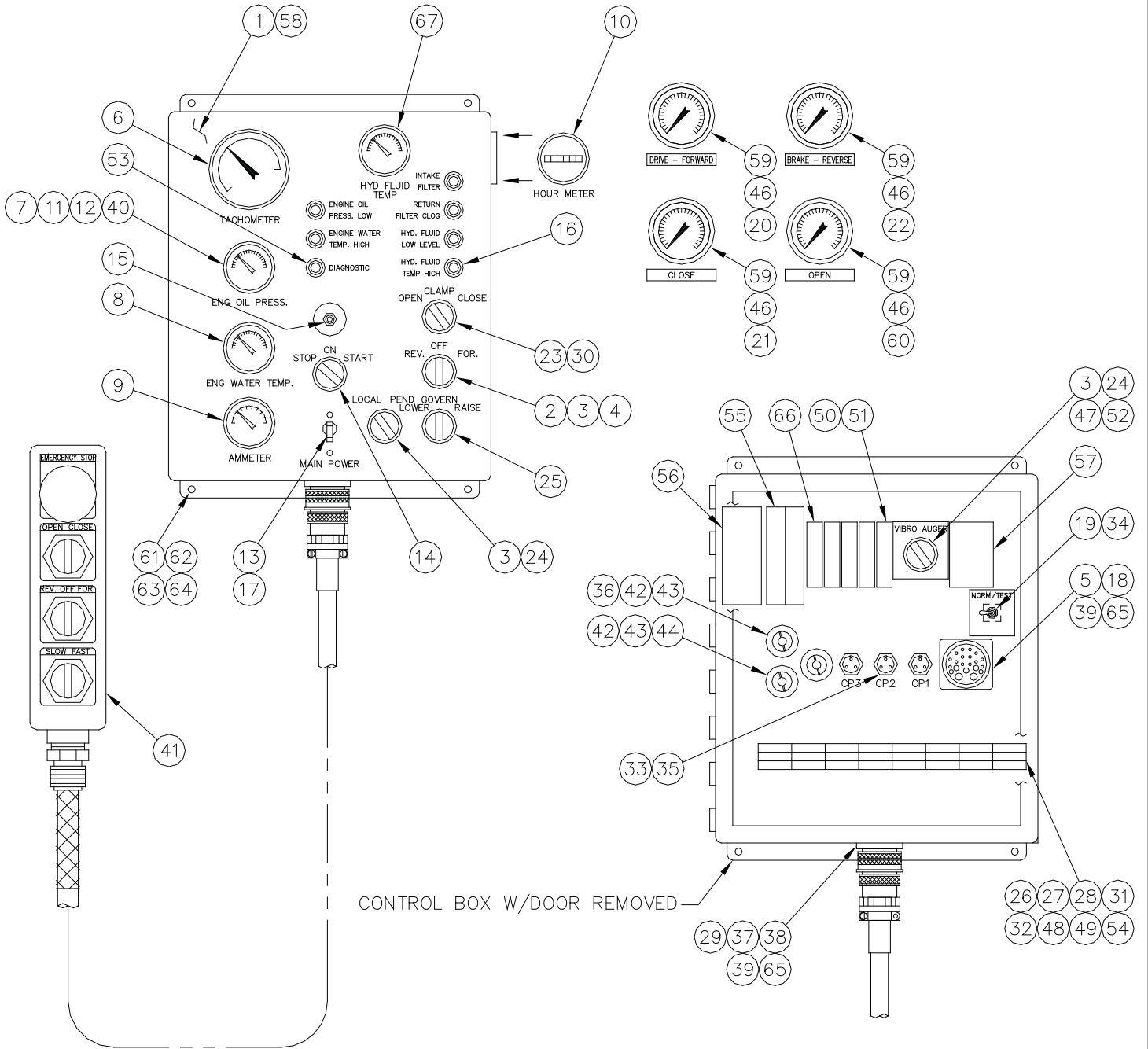



MODEL 44-50
VIBRATORY
DRIVER/EXTRACTOR

PARTS LIST

CONTROL BOX

810917

| Item | Part Number | Qty. | Description |
|------|-------------|------|------------------------------|
| 1 | 170835 | 1 | Enclosure |
| 2 | 170841 | 1 | Drive For/Rev Switch |
| 3 | 170901 | 5 | Contact Block 1 N.O. 1 N.C. |
| 4 | 170903 | 1 | Contact Block 1 N.O. |
| 5 | 170845 | 1 | Engine Receptacle |
| 6 | 170905 | 1 | Tachometer |
| 7 | 100329 | 1 | Oil Pressure Gage |
| 8 | 110697 | 1 | Water Temp Gage |
| 9 | 110371 | 1 | Voltmeter |
| 10 | 100343 | 1 | Hour Meter |
| 11 | 170939 | 1 | HOSE025BSSJ004J004L04200 |
| 12 | 170941 | 1 | FITT2L-04M02Q000-0000002 |
| 13 | 400141 | 1 | Circuit Breaker, 10 Amp |
| 14 | 110615 | 1 | Engine Control Switch |
| 15 | 130257 | 1 | Shutdown Reset |
| 16 | 170875 | 2 | Red L.E.D. |
| 17 | 100331 | 2 | #6-32 X 0.25 Lg BHCS |
| 18 | 170847 | 1 | Engine Receptacle Gasket |
| 19 | 170853 | 1 | Toggle Switch |
| 20 | 110680 | 1 | HOSE025AQ1J004J004L40000 |
| 21 | 170909 | 1 | HOSE025AQ1J004J004L03900 |
| 22 | 170911 | 1 | HOSE025AQ1J004J004L07900 |
| 23 | 170837 | 1 | Clamp Open/ Close Switch |
| 24 | 170843 | 1 | Local/ Pendant Switch |
| 25 | 100566 | 1 | Governor Raise/Lower Switch |
| 26 | 400161 | 2 | #10 Lock Washer |
| 27 | 400163 | 2 | #10-32 Hex Nut |
| 28 | 110649 | 2 | #10-32 X 0.375 Lg PHMS |
| 29 | 170861 | 1 | Pendant Receptacle Cover |
| 30 | 130305 | 1 | Light Bulb |
| 31 | 170877 | 30 | Terminal Bock |
| 32 | 170879 | 2 | Terminal Block |
| 33 | 170849 | 3 | S/O. Cord Receptacle |
| 34 | 170855 | 1 | Switch Bracket |
| 35 | 110843 | 3 | 0.50 Lock Nut |
| 36 | 170863 | 1 | 0.75 - 0.38 - 0.50 Connector |
| 37 | 170857 | 1 | Pendant Receptacle |
| 38 | 170859 | 1 | Pendant Receptacle Gasket |
| 39 | 110754 | 8 | #6-32 X 0.375 Lg RHMS |
| 40 | 300611 | 1 | FITT2S-02P04E000-000H002 |



MODEL 44-50
VIBRATORY
DRIVER/EXTRACTOR

PARTS LIST



MODEL 44-50
VIBRATORY
DRIVER/EXTRACTOR

PARTS LIST

CONTROL BOX

810917

| Item | Part Number | Qty. | Description |
|------|-------------|------|--------------------------------|
| 41 | 800591 | 1 | Pendant Assembly |
| 42 | 170865 | 3 | 0.75 Lock Nut |
| 43 | 170867 | 3 | 0.75 Rubber Gasket |
| 44 | 170869 | 1 | 0.75 Connector |
| 46 | 100321 | 4 | FITT2L-04M04Q000-0000001 |
| 47 | 170960 | 1 | Vibro-Auger Label |
| 48 | 170881 | 1 | Terminal End Section |
| 49 | 170883 | 2 | Terminal End Clamp |
| 50 | 170887 | 2 | Relay, 1 Pole |
| 51 | 170885 | 2 | Relay Base, 1 Pole |
| 52 | 170958 | 1 | Lagre Z Bracket |
| 53 | 170956 | 1 | Amber L.E.D. |
| 54 | 100413 | 8 | Diode, 6 Amp |
| 55 | 170871 | 2 | Circuit Breaker, 16 Amp |
| 56 | 170873 | 1 | Tach Transducer |
| 57 | 170893 | 1 | Speed Switch |
| 58 | 170962 | 1 | Faceplate Label |
| 59 | 110600 | 4 | 0-6000 PSI Gage |
| 60 | 170913 | 1 | HOSE025AQ1J004J004L04200 |
| 61 | 100576 | 4 | 0.25-20 X 0.625 Lg SHCS |
| 62 | 100559 | 4 | 0.25 Lock Washer |
| 63 | 100598 | 4 | 0.25-20 Hex Nut |
| 64 | 100597 | 4 | 0.25 Flat Washer |
| 65 | 110696 | 8 | #6 Lock Washer |
| 66 | 170954 | 1 | In-Line Time Delay Solid State |
| 67 | 110640 | 1 | Hyd. Temp. Gage |
| 68 | 130910 | 1 | Dust Cover |



MODEL 44-50
VIBRATORY
DRIVER/EXTRACTOR

PARTS LIST

PENDANT ASSEMBLY

800591

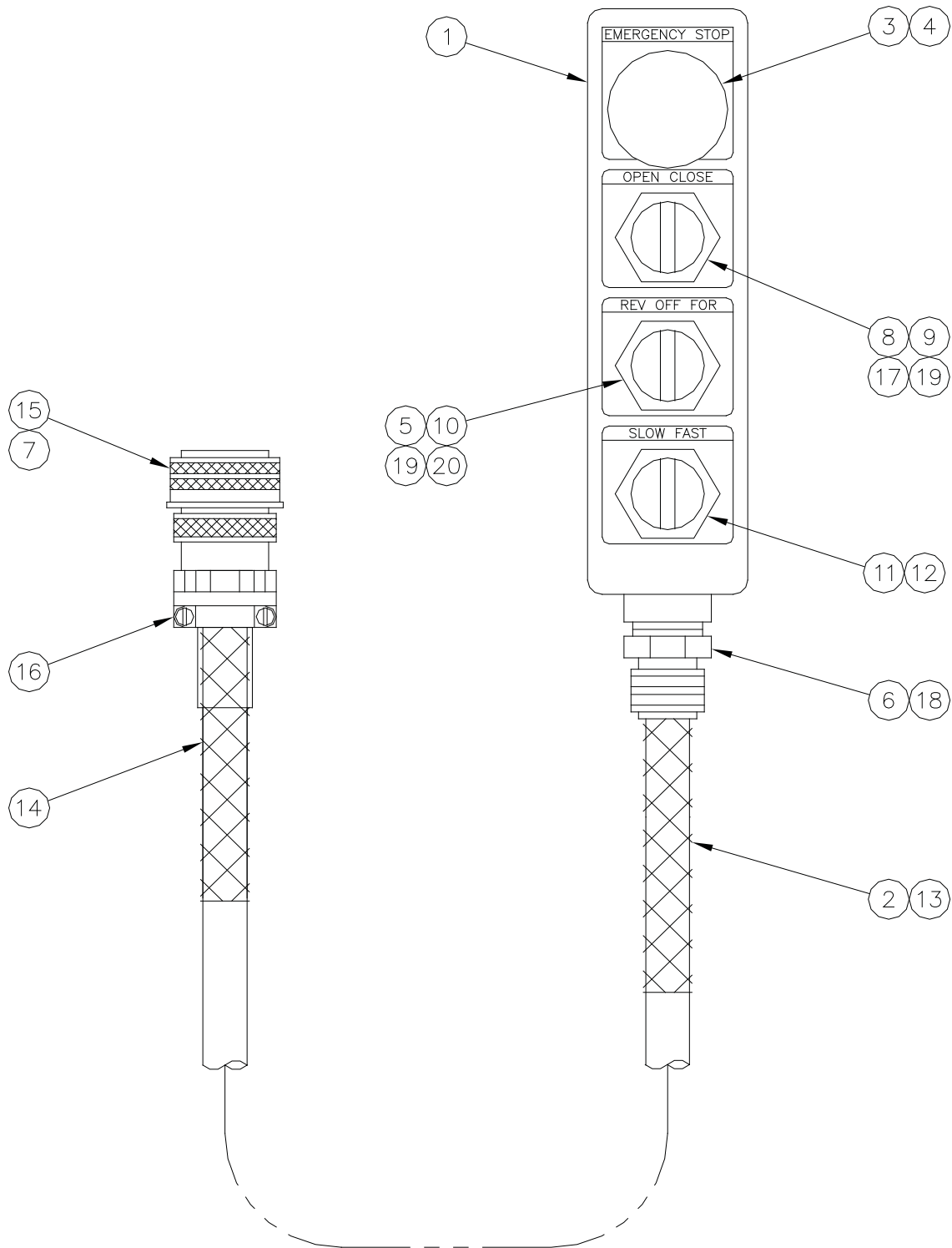



MODEL 44-50
VIBRATORY
DRIVER/EXTRACTOR

PARTS LIST

PENDANT ASSEMBLY

800591

| Item | Part Number | Qty. | Description |
|------|-------------|------|------------------------------|
| 1 | 130153 | 1 | Pendant Box |
| 2 | 110603 | 1 | Cord Grip Pendant End |
| 3 | 130507 | 1 | Emergency Stop Button |
| 4 | 130509 | 1 | Emergency Stop Label |
| 5 | 170841 | 1 | Drive For/Rev Switch |
| 6 | 170865 | 1 | 0.75 Lock Nut |
| 7 | 170899 | 1 | Pendant Receptacle Cover |
| 8 | 170837 | 1 | Clamp Open/ Close Switch |
| 9 | 100401 | 1 | Clamp Open/ Close Label |
| 10 | 100864 | 1 | Rev/Off/Fwd Label |
| 11 | 100566 | 1 | Governor Raise/ Lower Switch |
| 12 | 100562 | 1 | Lower/Governor/Raise Label |
| 13 | 100560 | 50 | Pendant Cable |
| 14 | 170839 | 1 | Cord Grip Plug End |
| 15 | 170857 | 1 | Pendant Receptacle |
| 16 | 170897 | 1 | Receptacle Clamp |
| 17 | 130305 | 1 | Light Bulb |
| 18 | 170867 | 1 | 0.75 Rubber Gasket |
| 19 | 100413 | 3 | Diode, 6 Amp |
| 20 | 170901 | 1 | Contact Block 1 N.O. 1 N.C. |



MODEL 44-50
VIBRATORY
DRIVER/EXTRACTOR

PARTS LIST

POWER UNIT - INTERNAL

800595

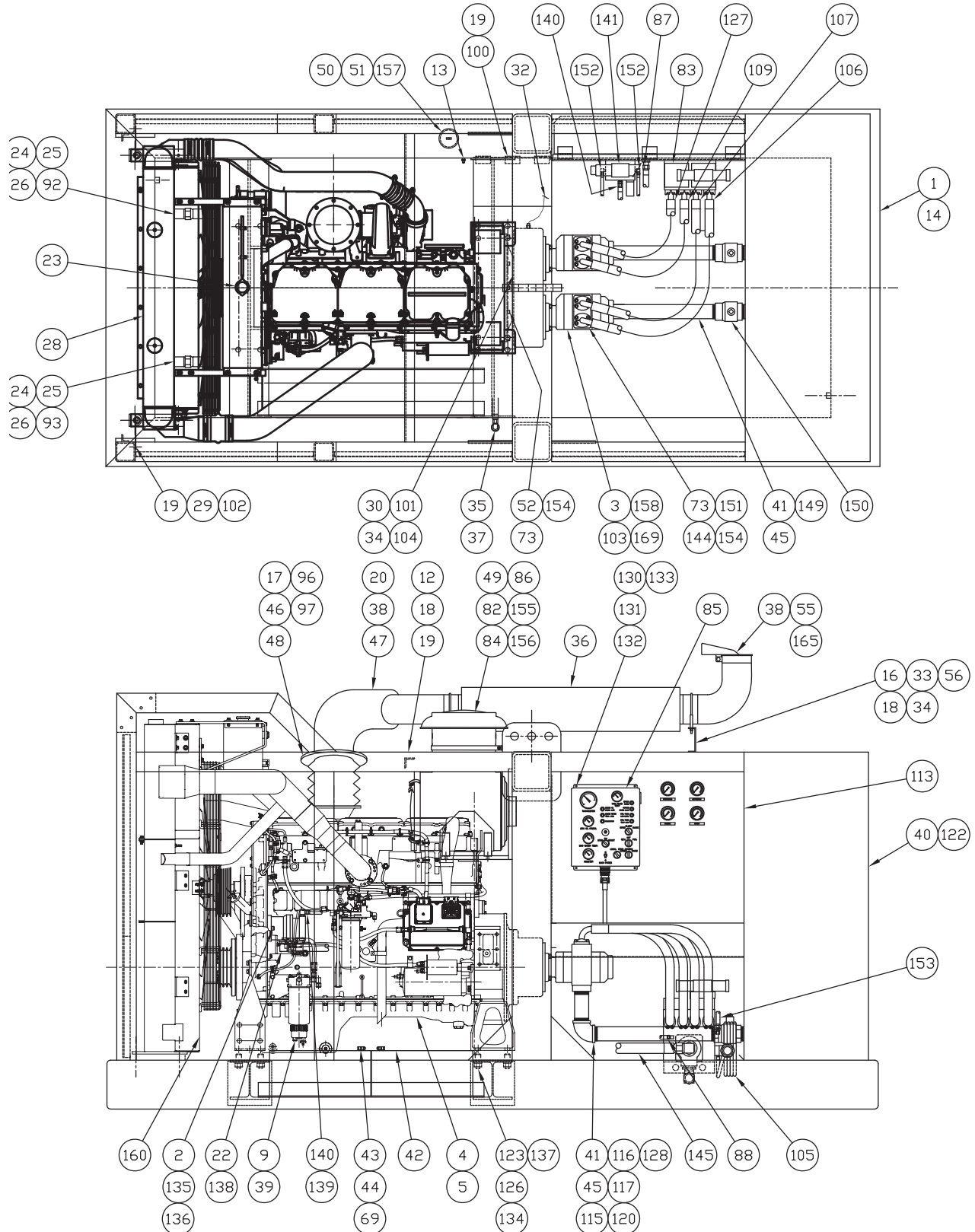



MODEL 44-50
VIBRATORY
DRIVER/EXTRACTOR

PARTS LIST

POWER UNIT - INTERNAL

800595

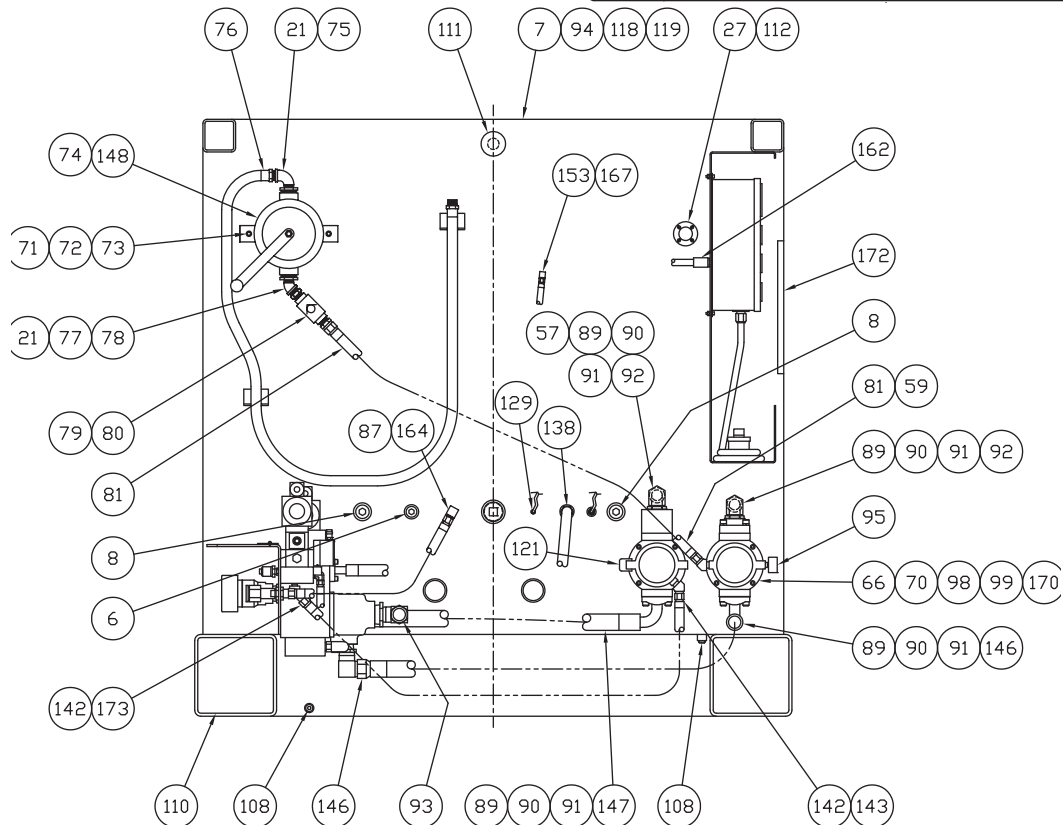
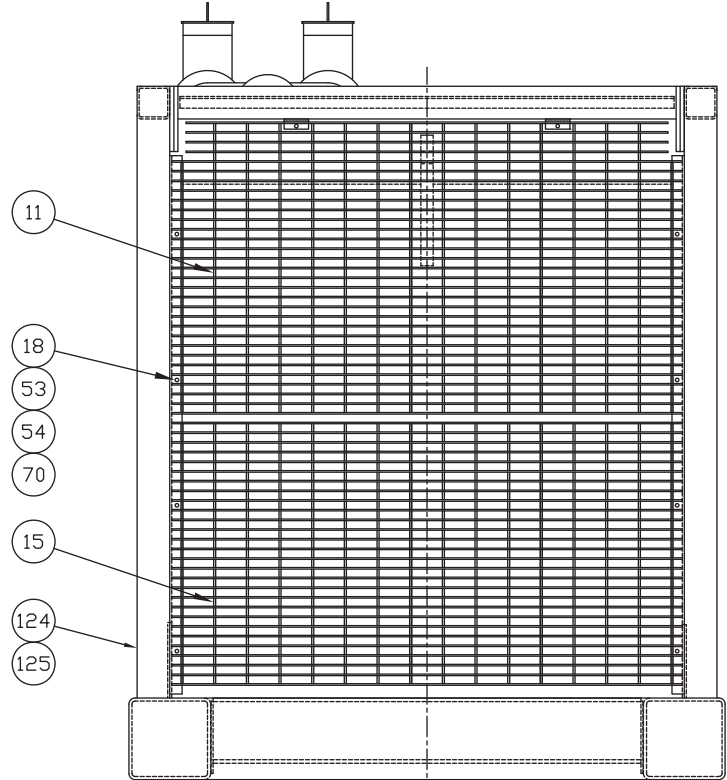
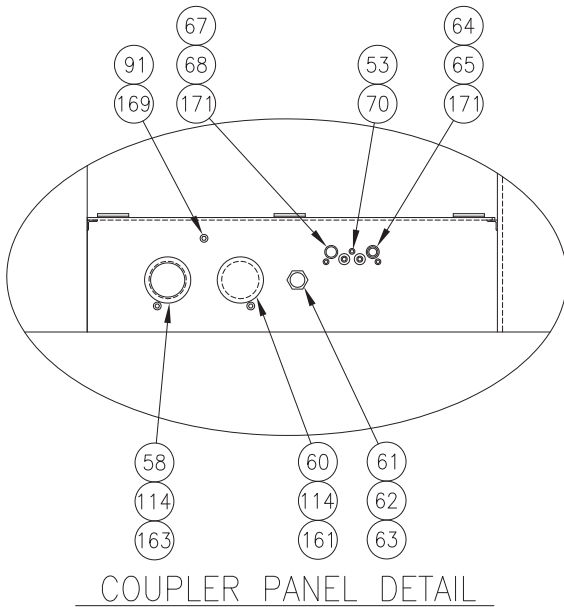



**MODEL 44-50
VIBRATORY
DRIVER/EXTRACTOR**

PARTS LIST

POWER UNIT - INTERNAL

800595

| <u>Item</u> | <u>Part Number</u> | <u>Qty.</u> | <u>Description</u> |
|-------------|------------------------|-------------|-------------------------------|
| 1 | 610011 | 1 | 580 SUBBASE ASM |
| 2 | 110401 | 1 | CLAMP PUMP |
| 3 | 110490 | 2 | 570D DRIVE PUMP |
| 4 | 170946 | 1 | C-15 DIESEL ENGINE |
| 5 | 400247 | 38 | ENGINE OIL/QUART |
| 6 | 100063 | 1 | FITT2P-16P000000-000S007 |
| 7 | 170872 | 28 | 0.38-16 UNC X 1.00 LG SHSC SS |
| 8 | 110055 | 2 | FITT2P-20P000000-000S007 |
| 9 | 170931 | 1 | FUEL WATER SEPARATOR |
| 10 | 110369 | 1 | FITT2S-06P04Q000-000H001 |
| 11 | 610442 | 1 | INTAKE FRONT TOP GRATING |
| 12 | 610444 | 1 | EXHAUST RIGHT GRATING |
| 13 | 110203 | 1 | FITT2S-04M04P000-000H001 |
| 14 | 810919 | 1 | 580 POWER UNIT ENCLOSURE |
| 15 | 610450 | 1 | INTAKE FRONT BOTT GRATING |
| 16 | 100396 | 8 | .312-18UNC x 1.50 LG. SHCS |
| 17 | 170908 | 16 | 0.88-9 UNC HEX NUT |
| 18 | 100398 | 30 | SADDLE CLIP |
| 19 | 110830 | 40 | .25 X 2 IN. HEX TEX SCREW |
| 20 | 610448 | 1 | EXHAUST ADPT WELDMENT |
| 21 | 110089 | 2 | FITT2S-20P16Q000-000H001 |
| 22 | 100783 | 1 | FITT2L-16M16R000-000H001 |
| 23 | 100726 | 15 | ANTIFREEZE/GAL |
| 24 | 110443 | 2 | FITT2L-24M24Q000-0000001 |
| 25 | 110437 | 2 | FITT2S-24P24P000-0550301 |
| 26 | 100547 | 2 | FITT2S-32P24Q000-000H006 |
| 27 | 110564 | 4 | .25-20 x 2.25 LG RHMS |
| 28 | 110102 | 1 | TRIPLE CORE COOLER C-15 |
| 29 | 110112 | 2 | SIDE AIR BAFFLE |
| 30 | 140803 | 8 | .5-13UNC X 1.00 LG HHCS |
| 31 | 400151 | 50 | .375 FLAT WASHER |
| 32 | 100408 | 1 | MAGNETIC PICK-UP(300-570) |
| 33 | 100289 | 8 | .312-18 HEX NUT |
| 34 | 100287 | 8 | .312 LOCK WASHER |
| 35 | 400227 | 1 | FITT2L-06M06P000-0000001 |
| 36 | 110504 | 2 | MUFFLER |
| 37 | 100715 | 1 | FITT2S-16P06Q000-000H001 |
| 38 | 100297 | 4 | EXHAUST PIPE CLAMP |
| 39 | 170864 | 1 | WATER SEPARATOR ASM |
| 40 | 140415 | 435 | HYDRAULIC FLUID/GAL |



MODEL 44-50
VIBRATORY
DRIVER/EXTRACTOR

PARTS LIST

POWER UNIT - INTERNAL

800595

| Item | Part Number | Qty. | Description |
|------|-------------|------|-------------------------------|
| 41 | 170926 | 4 | FITT2S-40P40T000-000001 |
| 42 | 150081 | 2 | BATTERY |
| 43 | 110653 | 1 | BATTERY CABLE-6 |
| 44 | 170918 | 1 | BATTERY CABLE 28" |
| 45 | 170922 | 4 | 2.50 HOSE CLAMP |
| 46 | 170914 | 1 | FLEX ASSEMBLY 8" |
| 47 | 170912 | 1 | GASKET 8" ANSI |
| 48 | 170910 | 1 | GASKET 8" CATERPILLAR |
| 49 | 170902 | 1 | 6" HUMP HOSE |
| 50 | 100417 | 1 | FITT2C-48Q000000-0000306 |
| 51 | 100419 | 1 | PETCOCK |
| 52 | 110138 | 1 | HUB SUPPORT FLEX PLATE |
| 53 | 400149 | 27 | .375 LOCK WASHER |
| 54 | 100535 | 54 | .375 -16 HEX NUT |
| 55 | 110506 | 2 | MUFFLER OUTLET ELBOW |
| 56 | 110342 | 4 | MUFFLER SUPPORT |
| 57 | 110140 | 1 | RETURN FILTER FLANGE BLOCK |
| 58 | 110957 | 1 | 1.50 DUST PLUG |
| 59 | 110641 | 1 | FITT2V-12M08P000-0000001 |
| 60 | 110955 | 1 | 1.50 DUST CAP |
| 61 | 100387 | 1 | FITT2S-12P12B000-000H001 |
| 62 | 400095 | 1 | .75 FEMALE DISCONNECT |
| 63 | 400121 | 1 | .75 DUST PLUG |
| 64 | 100245 | 1 | .375 MALE DISCONNECT |
| 65 | 100257 | 1 | .375 DUST CAP |
| 66 | 110110 | 2 | RETURN FILTER GASKET |
| 67 | 100777 | 1 | .375 FEMALE DISCONNECT |
| 68 | 100737 | 1 | .375 DUST PLUG |
| 69 | 170916 | 1 | BATTERY CABLE 20" |
| 70 | 100051 | 19 | .375-16 X 1.0 LG SHCS LOC WEL |
| 71 | 100439 | 2 | .437-X1.75 LG SHCS |
| 72 | 400153 | 2 | .437 FLAT WASHER |
| 73 | 100443 | 32 | .437 LOCK WASHER |
| 74 | 100447 | 1 | HAND PUMP |
| 75 | 110377 | 1 | FITT2L-16P16Q000-0000306 |
| 76 | 400215 | 1 | HOSE100R01P016P016L08400 |
| 77 | 110385 | 1 | FITT2V-16P16Q000-0000306 |
| 78 | 100449 | 1 | FITT2S-16P16P000-000H001 |
| 79 | 100451 | 1 | CHECK VALVE |
| 80 | 300119 | 1 | FITT2S-16P12M000-000H001 |



MODEL 44-50
VIBRATORY
DRIVER/EXTRACTOR

PARTS LIST

POWER UNIT - INTERNAL

800595

| Item | Part Number | Qty. | Description |
|------|-------------|------|------------------------------|
| 81 | 110130 | 1 | HOSE075R01J012J012L05900 |
| 82 | 110431 | 6 | 6in BAND CLAMP |
| 83 | 810447 | 1 | 570D CONTROL MANIFOLD ASM. |
| 84 | 110429 | 2 | AIR INTAKE ELBOW |
| 85 | 810917 | 1 | 580 CONTROL BOX ASM |
| 86 | 110427 | 1.5 | AIR INTAKE TUBE PER FT |
| 87 | 170874 | 1 | HOSE075R01J012J012L04150 |
| 88 | 170932 | 1 | HOSE025R02J004J004L10700 |
| 89 | 100596 | 4 | #24 SPLIT FLANGE HALF |
| 90 | 110119 | 4 | 2-225 O-RING |
| 91 | 100119 | 4 | .5-13 X 1.25 LG SHCS LOC WEL |
| 92 | 170936 | 1 | HOSE150R01J024F924L17200 |
| 93 | 170938 | 1 | HOSE150R01J024J024L13450 |
| 94 | 170870 | 28 | 0.38 LOCK WASHER S.S. |
| 95 | 100436 | 1 | GAGE (0-100 P.S.I.) |
| 96 | 170904 | 16 | 0.88 LOCK WASHER |
| 97 | 170906 | 16 | 0.88-9 UNC X 2.50 HHCS |
| 98 | 110118 | 2 | FILTER ASSEMBLY |
| 99 | 810117 | 4 | K10 ELEMENT ASSEMBLY |
| 100 | 100558 | 1 | TOOL BOX |
| 101 | 110108 | 1 | DOUBLE PUMP DRIVE C-15 |
| 102 | 110106 | 68 | FOAM TUBING / INCH |
| 103 | 100614 | 8 | .5-13 UNC X 1.50 LG HHCS |
| 104 | 110444 | 2 | TRANSMISSION OIL / GAL. |
| 105 | 110680 | 1 | HOSE025R02J004J004L40000 |
| 106 | 110474 | 1 | HOSE100PT4F016F920L05250 |
| 107 | 110476 | 1 | HOSE100PT4F016F920L04800 |
| 108 | 100423 | 4 | FITT2P-08P000000-000S007 |
| 109 | 110478 | 1 | HOSE100PT4F016F920L04500 |
| 110 | 100725 | 150 | DIESEL FUEL/GAL |
| 111 | 100455 | 1 | BREATHER |
| 112 | 100314 | 1 | FLOAT SWITCH |
| 113 | 110355 | 1 | LEVEL GAUGE |
| 114 | 110392 | 2 | FITT2S-24R24P000-000H001 |
| 115 | 400015 | 2 | 2.5 SOLID FLANGE |
| 116 | 400379 | 2 | 2-232 O-RING 90 DURO |
| 117 | 110735 | 8 | .5-13 X 2.5 LG SHCS |
| 118 | 110146 | 1 | RESERVOIR COVER PLATE |
| 119 | 110144 | 1 | COVER GASKET |
| 120 | 170930 | 2 | FITT2L-40Q40Q000-0000306 |



MODEL 44-50
VIBRATORY
DRIVER/EXTRACTOR

PARTS LIST

POWER UNIT - INTERNAL

800595

| Item | Part Number | Qty. | Description |
|------|-------------|------|----------------------------|
| 121 | 100602 | 1 | PRESSURE SWITCH |
| 122 | 610287 | 1 | HYD RESERVOIR |
| 123 | 140111 | 12 | .75-10 X 4.0 LG SHCS LW |
| 124 | 100299 | 6 | PRIMER/GAL |
| 125 | 100298 | 6 | APE / J&M YELLOW PAINT/GAL |
| 126 | 100587 | 12 | .75-10 HEX NUT |
| 127 | 110100 | 1 | HOSE100PT4F016F920L04250 |
| 128 | 170928 | 1 | FITT2S-40P40P000-050301 |
| 129 | 110590 | 1 | HYDRAULIC TEMPERATURE |
| 130 | 100557 | 4 | .25-20 x .75 LG SHCS |
| 131 | 100598 | 4 | .25-20 HEX NUT |
| 132 | 100597 | 4 | .25 FLAT WASHER |
| 133 | 100559 | 4 | .25 LOCK WASHER |
| 134 | 100069 | 12 | .75 LOCK WASHER MEDIUM |
| 135 | 100513 | 8 | .5-13 X 1.5 LG SHCS |
| 136 | 100027 | 2 | .5 HI-COLLAR LOCK WASHER |
| 137 | 100589 | 12 | .75 FLAT WASHER |
| 138 | 110122 | 1 | HOSE100R01P016J016L10100 |
| 139 | 100787 | 1 | FITT2L-08M08R000-000H001 |
| 140 | 170920 | 1 | HOSE050PT4J008J008L08700 |
| 141 | 810449 | 1 | CLAMP MANIFOLD ASM |
| 142 | 300481 | 1 | FITT2L-12M08P000-0000001 |
| 143 | 170934 | 1 | HOSE075R01J012J012L05700 |
| 144 | 100037 | 4 | 2-222 O-RING 90 DURO |
| 145 | 170940 | 1 | HOSE150R01J024J024L04250 |
| 146 | 110780 | 1 | HOSE150R01J024F924L04900 |
| 147 | 170942 | 1 | HOSE150R01F924J024L03400 |
| 148 | 130091 | 1 | PUMP MOUNTING BRACKET |
| 149 | 170924 | 2 | HOSE250R0400000000L01600 |
| 150 | 400117 | 2 | STOP COCK |
| 151 | 100045 | 8 | #20 PA SPLIT FLANGE HALF |
| 152 | 130207 | 2 | HOSE019R01J004J004L10000 |
| 153 | 110120 | 1 | HOSE038R02J006J006L06900 |
| 154 | 100462 | 28 | .437-14 UNC X 1.25 LG HHCS |
| 155 | 170882 | 1 | AIR FILTER INNER ELEMENT |
| 156 | 170884 | 1 | AIR FILTER OUTER ELEMENT |
| 157 | 300197 | 1 | FITT2L-04P04Q000-0000306 |
| 158 | 120683 | 2 | 248-O-RING |
| 159 | 110909 | 1 | .75 X 15 LG PIPE SCH40 |
| 160 | 100588 | 1 | FITT2L-24M24P000-0000001 |



MODEL 44-50
VIBRATORY
DRIVER/EXTRACTOR

PARTS LIST



MODEL 44-50
VIBRATORY
DRIVER/EXTRACTOR

PARTS LIST

POWER UNIT - INTERNAL

800595

| Item | Part Number | Qty. | Description |
|------|-------------|------|-------------------------------|
| 161 | 110690 | 1 | 1.50 MALE DISCONNECT |
| 162 | 120895 | 3 | S/O CORD SPLIT END 25 FEET LG |
| 163 | 110692 | 1 | 1.50 FEMALE DISCONNECT |
| 164 | 100489 | 1 | FITT2L-12M12P000-0000001 |
| 165 | 110695 | 2 | RAIN CAP |
| 166 | 170876 | 1 | OIL FILTER |
| 167 | 140581 | 1 | FITT2L-06M04P000-0000001 |
| 168 | 170878 | 1 | FUEL FILTER |
| 169 | 100121 | 11 | .50 LOCK WASHER MEDIUM |
| 170 | 110864 | 2 | CHECK VALVE |
| 171 | 110794 | 2 | FITT2S-06P06P000-000H001 |
| 172 | 170902 | 1 | DOCUMENT HOLDER |
| 173 | 300231 | 1 | FITT2V-12M12J |



MODEL 44-50
VIBRATORY
DRIVER/EXTRACTOR

PARTS LIST

CONTROL MANIFOLD ASSEMBLY

810447

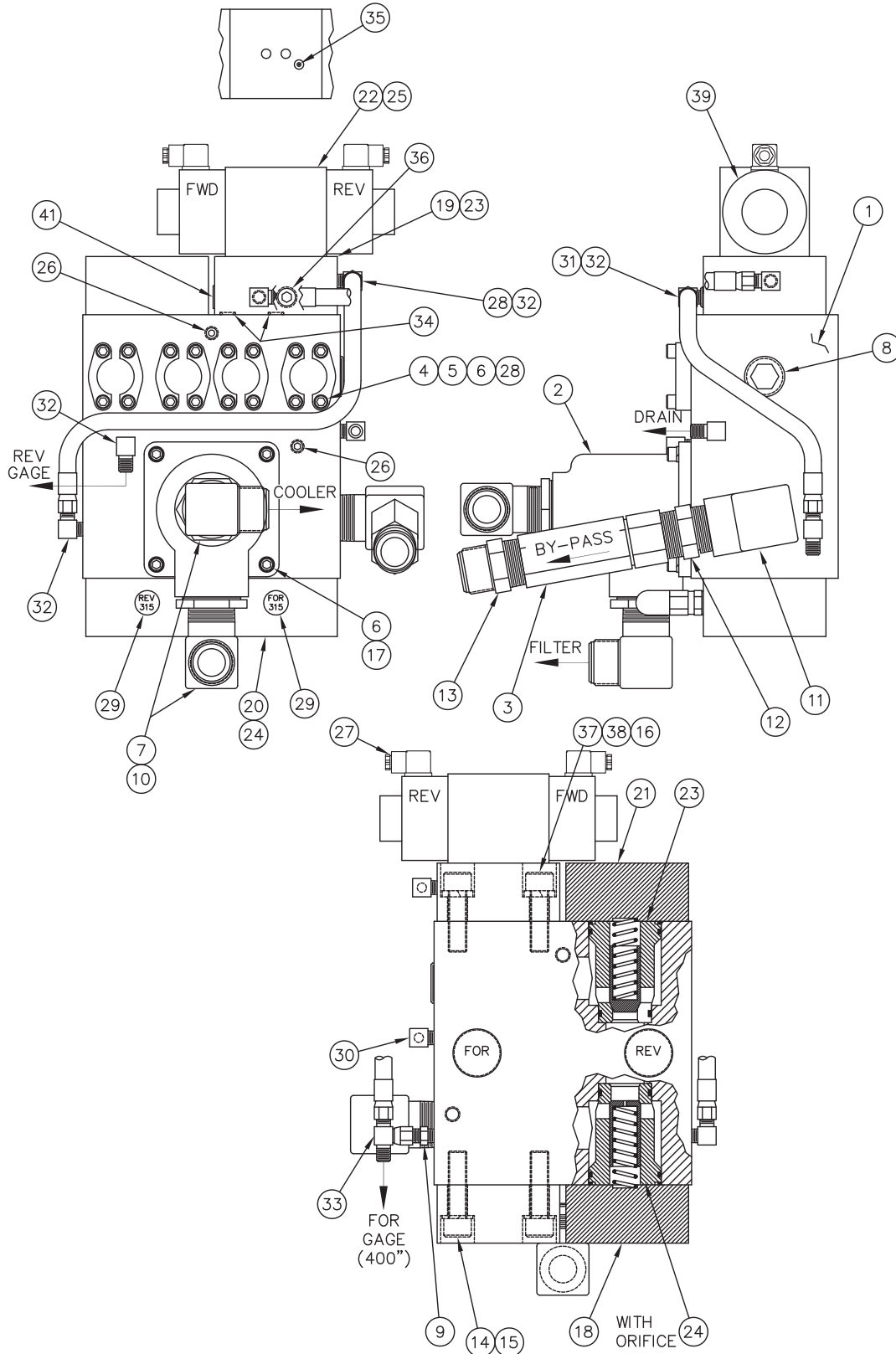



MODEL 44-50
VIBRATORY
DRIVER/EXTRACTOR

PARTS LIST

CONTROL MANIFOLD ASSEMBLY

810447

| Item | Part Number | Qty. | Description |
|------|-------------|------|--------------------------------|
| 1 | 110516 | 1 | Manifold Block |
| 2 | 110628 | 1 | Cooler Valve (V3) |
| 3 | 130339 | 1 | Check Valve (CV3) |
| 4 | 100089 | 8 | #16 Split Flange Half |
| 5 | 100091 | 4 | #219-O-Ring |
| 6 | 100143 | 20 | .375-16UNC x 1.25 Lg SHCS |
| 7 | 100588 | 2 | FITT2L-24M24P000-0000001 |
| 8 | 110055 | 1 | FITT2P-20P000000-000S007 |
| 9 | 110203 | 1 | FITT2S-04M04P000-000H001 |
| 10 | 100547 | 2 | FITT2S-32P24Q000-000H001 |
| 11 | 100446 | 1 | FITT2L-24P24Q000-000H001 |
| 12 | 110037 | 1 | FITT2S-24P24P000-000H001 |
| 13 | 100565 | 1 | FITT2S-24P24M000-000H001 |
| 14 | 400039 | 12 | .75-10UNC x 2.75 Lg SHCS |
| 15 | 100069 | 12 | .75 Lock Washer |
| 16 | 110616 | 1 | .25 X .625 Lg Roll Pin |
| 17 | 400149 | 4 | .375 Lock Washer |
| 18 | 110544 | 1 | Cartridge Cover (CC4) |
| 19 | 110262 | 1 | Cartridge Cover (CC1) |
| 20 | 110546 | 1 | Cartridge Cover (CC2) |
| 21 | 110606 | 1 | Cartridge Cover (CC3) |
| 22 | 110260 | 4 | .25-20UNC x 2.75 Lg, SHCS |
| 23 | 110624 | 2 | Cartridge A (CA1-2) |
| 24 | 110622 | 2 | Cartridge B (CB1-2) |
| 25 | 120899 | 1 | Control Valve DIN Connect (V2) |
| 26 | 100845 | 2 | FITT2P-04P000000-000S007 |
| 27 | 120897 | 2 | Lighted DIN Connector |
| 28 | 100719 | 1 | HOSE025R02J004J004L03000 |
| 29 | 100632 | 2 | Relief Cartridge (315) |
| 30 | 140581 | 1 | FITT2L-04P06M000-0000001 |
| 31 | 100149 | 1 | HOSE025R02J004J004L01900 |
| 32 | | 4 | FITT2L-04M06R000-0000001 |
| 33 | 100556 | 1 | FITT2T-04M04M04J-0000001 |
| 34 | 110602 | 2 | #111-O-Ring |
| 35 | 140387 | 1 | Orifice |
| 36 | | 1 | FITT2P-10R000000-000S007 |
| 37 | 100067 | 4 | .75-10 X 2.50 Lg SHCS Lockwel |
| 38 | 400727 | 4 | .75 Hi-Collar Lock Washer |
| 39 | 120891 | 2 | Solenoid for 120899 It. 25 |
| 40 | 120925 | 1 | S/O Cord Split End 15 feet Lg |
| 41 | 400992 | 1 | FITT2P-06R |



MODEL 44-50
VIBRATORY
DRIVER/EXTRACTOR

PARTS LIST

CLAMP MANIFOLD

810915

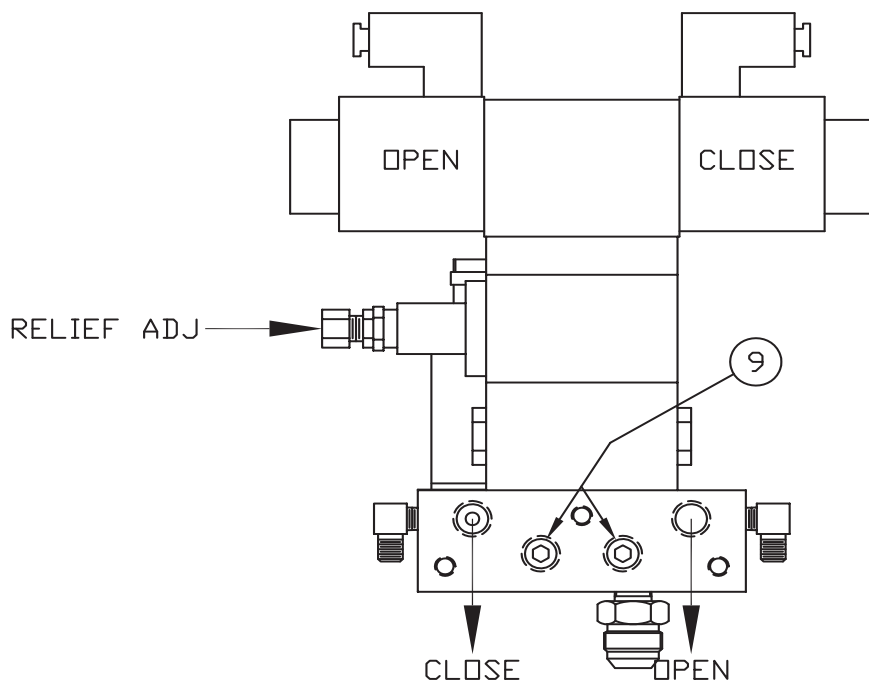
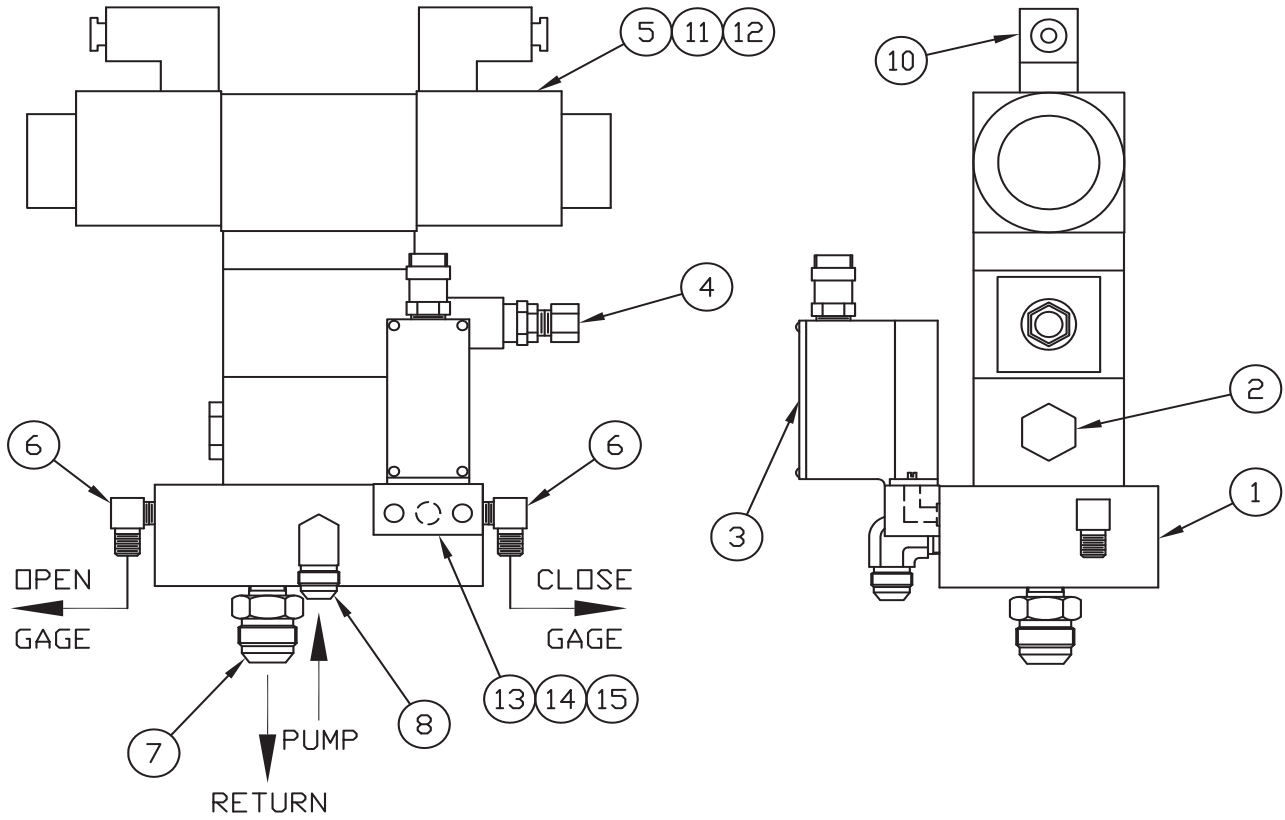



MODEL 44-50
VIBRATORY
DRIVER/EXTRACTOR

PARTS LIST

CLAMP MANIFOLD

810915

| Item | Part Number | Qty. | Description |
|------|-------------|------|---|
| 1 | 110642 | 1 | CLAMP MANIFOLD BLOCK |
| 2 | 110149 | 1 | CHECK VALVE |
| 3 | 810425 | 1 | PRESSURE SWITCH ASSEMBLY |
| 4 | 100898 | 1 | SANDWICH RELIEF |
| 5 | 120899 | 1 | CONTROL VALVE |
| 6 | 140539 | 2 | FITT2L-04M02P000-0000001 |
| 7 | 170974 | 1 | FITT2S-12M06P000-000H001 |
| 8 | 300341 | 1 | FITT2L-08M06P000-000H001 |
| 9 | 400213 | 2 | FITT2P-06P000000-000S007 |
| 10 | 120897 | 2 | LIGHTED DIN CONNECTOR |
| 11 | 170968 | 4 | 0.25-20 X 6.00 LG SHCS |
| 12 | 170970 | 4 | 0.25 Bolt Spacer 0.25 Thick |
| 13 | 110134 | 1 | Turning Manifold |
| 14 | 110167 | 2 | 10-32 X 1.00 SHCS |
| 15 | 110602 | 1 | 2-011 O-Ring |
| 16 | 120891 | 2 | Solenoid for 120899 lt. 5 |
| 17 | 110128 | 1 | Electrical Connector Board for 110147 lt. 5 |
| 18 | 160583 | 15 | 2-015 O-Ring between Valves |
| | 120925 | 1 | S/O CORD SPLIT END 156" LG |



MODEL 44-50
VIBRATORY
DRIVER/EXTRACTOR

PARTS LIST

126 CLAMP ASSEMBLY

800327

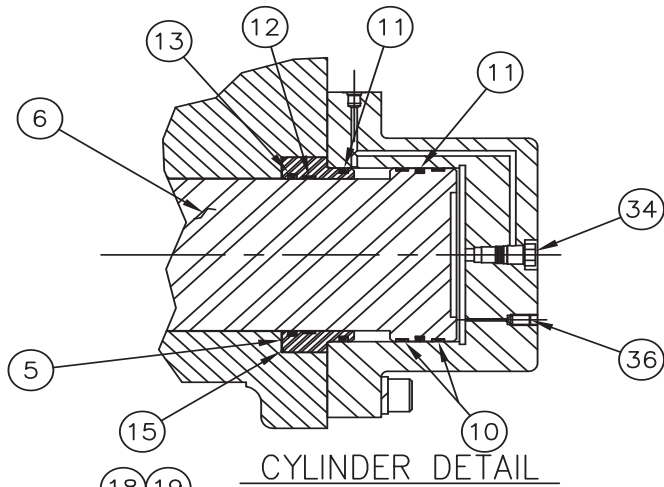

NOTE:

1. TORQUE 1.00 SOCKET HEAD CAP SCREWS TO 1000 FT/LB.

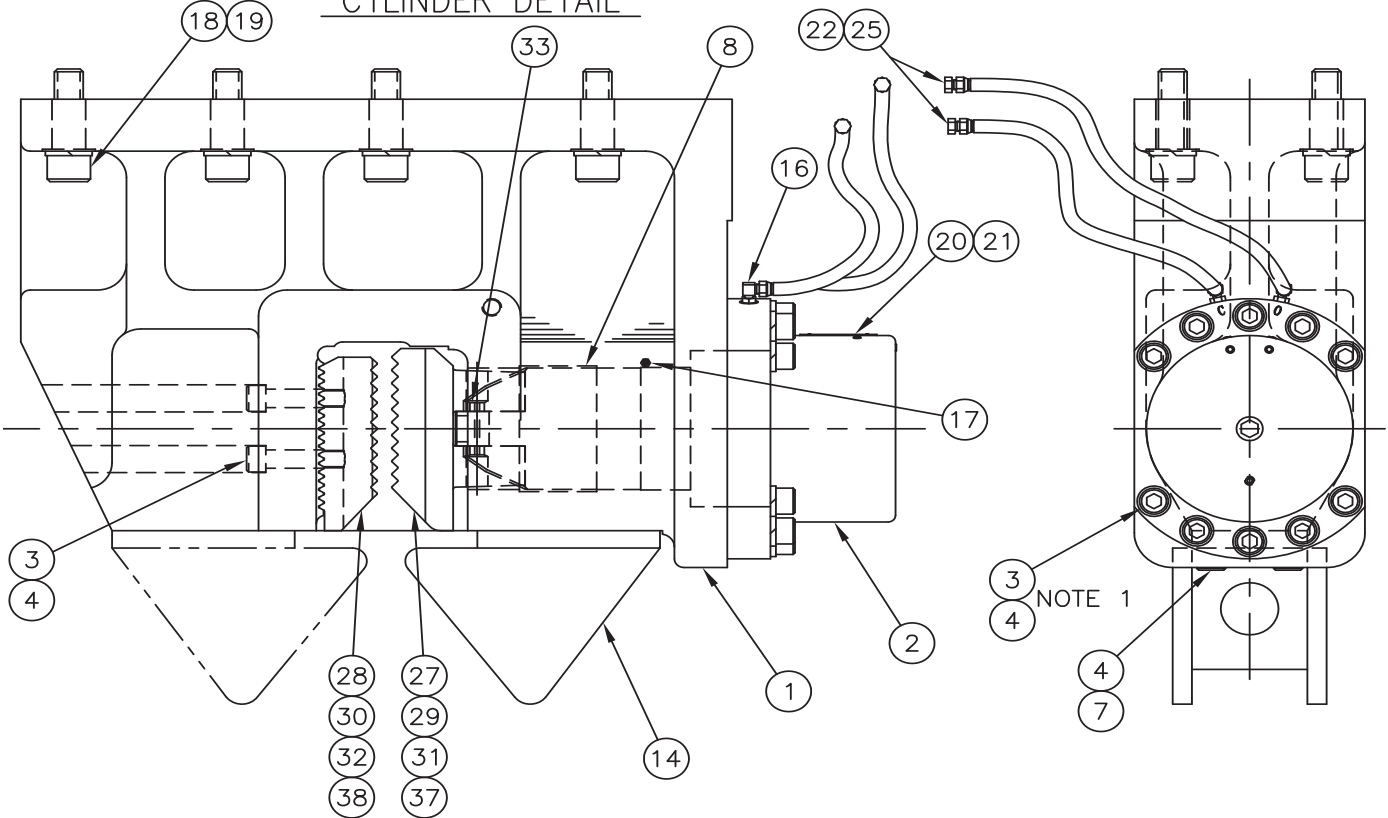



**MODEL 44-50
VIBRATORY
DRIVER/EXTRACTOR**

PARTS LIST

126 CLAMP ASSEMBLY

800327

| <u>Item</u> | <u>Part Number</u> | <u>Qty.</u> | <u>Description</u> |
|-------------|------------------------|-------------|-------------------------------|
| 1 | 810493 | 1 | 126 CLAMP BODY |
| 2 | 810491 | 1 | CYLINDER (126) |
| 3 | 100212 | 12 | 1.0-8 X 4.00 LG SHCS LOC WEL |
| 4 | 100209 | 17 | 1.00 LOCK WASHER MEDIUM |
| 5 | 120567 | 1 | ROD END CAP (126) |
| 6 | 120931 | 1 | PISTON / ROD (126) |
| 7 | 100213 | 7 | 1.0-8 X 2.50 LG SHCS LOC WEL |
| 8 | 120929 | 1 | ROD WEAR RING |
| 10 | 120285 | 2 | PISTON BEARING (Note 2) |
| 11 | 120283 | 2 | PISTON SEAL (Note 2) |
| 12 | 120555 | 1 | ROD BEARING (Note 2) |
| 13 | 120553 | 1 | ROD SEAL (Note 2) |
| 14 | 100983 | 1 | PILE FEED GUIDE |
| 15 | 120401 | 1 | 2-269 O-RING 90 DURO (Note 2) |
| 16 | 130057 | 2 | FITT2L-06M06R000-000H001 |
| 17 | 100229 | 1 | GREASE FITTING |
| 18 | 100193 | 8 | 1.5-6 X 5.0 LG SHCS |
| 19 | 100195 | 8 | 1.5 LOCK WASHER EXTRA HEAVY |
| 20 | 120365 | 1 | 126 S/N PLATE |
| 21 | 130381 | 4 | RIVET |
| 22 | 130561 | 2 | HOSE038R02J006J006L0700C |
| 23 | 100299 | 1 | PRIMER/GAL |
| 24 | 110156 | 1 | APE / J&M YELLOW PAINT/GAL |
| 25 | 100230 | 2 | FITT2P-06M000000-000T001 |
| 26 | 810515 | 1 | 126 SEAL KIT |
| 27 | 810495 | 1 | UNIVERSAL MOVABLE JAW (126) |
| 28 | 110515 | 1 | UNIVERSAL FIXED JAW-SER. |
| 29 | 810497 | 1 | H-BEAM MOVABLE JAW (126) |
| 30 | 110541 | 1 | H-BEAM JAW -FIXED |
| 31 | 810499 | 1 | DS MOVABLE JAW (126) |
| 32 | 110419 | 1 | DOUBLE SHEET FIXED JAW |
| 33 | 130449 | 1 | ROLL PIN .75 X 3" |
| 34 | 120629 | 1 | HOLDING VALVE CARTRIDGE |
| 36 | 120761 | 1 | POINTED SET SCREW |
| 37 | 810581 | 1 | 10" D.S. MOVEABLE JAW |
| 38 | 120619 | 1 | 10" D.S. FIXED JAW |

Note 2: Included in 126 Seal Kit 810515 Item 26



MODEL 44-50
VIBRATORY
DRIVER/EXTRACTOR

PARTS LIST

MODEL 127 CLAMP (OPTIONAL)

800041

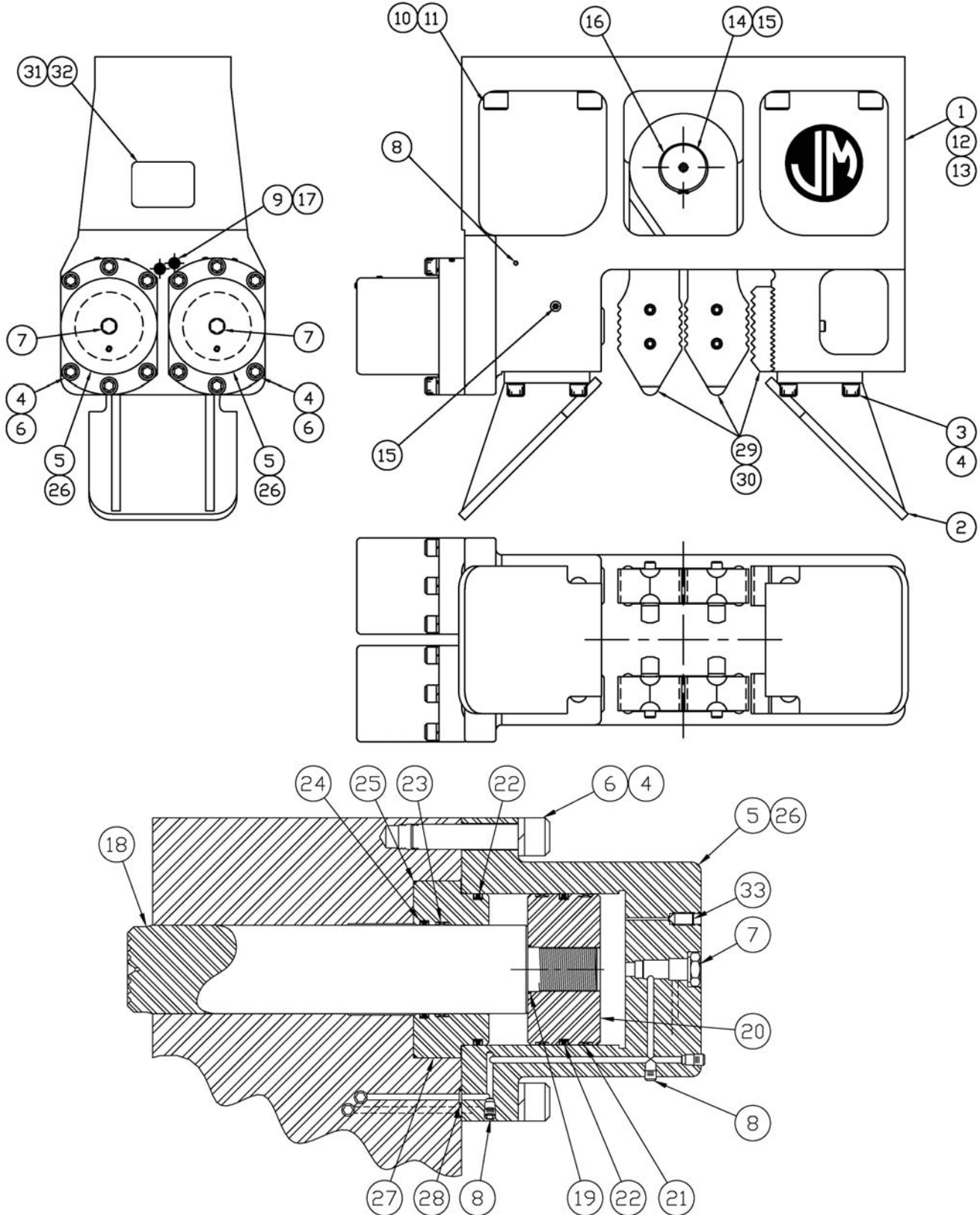



**MODEL 44-50
VIBRATORY
DRIVER/EXTRACTOR**

PARTS LIST

MODEL 127 CLAMP (OPTIONAL)

800041

| <u>Item</u> | <u>Part Number</u> | <u>Qty.</u> | <u>Description</u> |
|-------------|------------------------|-------------|---------------------------------|
| 1 | 810615 | 1 | 127 CLAMP BODY |
| 2 | 120677 | 2 | PILE GUIDE |
| 3 | 100213 | 8 | 1.0-8 X 2.50 LG SHCS LOC WEL |
| 4 | 100209 | 20 | 1.00 LOCK WASHER MEDIUM |
| 5 | 120659 | 2 | CYLINDER (127) |
| 6 | 100212 | 12 | 1.0-8 X 4.00 LG SHCS LOC WEL |
| 7 | 120629 | 2 | HOLDING VALVE CARTRIDGE |
| 8 | 100646 | 10 | FITT2P-02P000000-000S007 |
| 9 | 100053 | 2 | FITT2S-06M06R000-000H001 |
| 10 | 100193 | 8 | 1.5-6 X 5.0 LG SHCS |
| 11 | 100195 | 8 | 1.5 LOCK WASHER EXTRA HEAVY |
| 12 | 100299 | 1 | PRIMER/GAL |
| 13 | 110156 | 1 | APE / J&M YELLOW PAINT/GAL |
| 14 | 120155 | 1 | SHAFT |
| 15 | 100229 | 4 | GREASE FITTING |
| 16 | 120191 | 2 | RETAINER RING |
| 17 | 130561 | 2 | HOSE038R02J006J006L0700C |
| 18 | 120663 | 2 | CYLINDER ROD (127) |
| 19 | 120239 | 2 | 2-132 O-RING (NOTE 1) |
| 20 | 120241 | 2 | PISTON- (127) |
| 21 | 120243 | 4 | PISTON BEARING (NOTE 1) |
| 22 | 120245 | 4 | PISTON SEAL (NOTE 1) |
| 23 | 120665 | 2 | ROD BEARING (NOTE 1) |
| 24 | 120667 | 2 | ROD SEAL (NOTE 1) |
| 25 | 120347 | 2 | 2-261 O-RING 90 DURO (NOTE 1) |
| 26 | 810629 | 2 | 127 SEAL KIT |
| 27 | 120661 | 2 | ROD END CAP (NOTE 1) |
| 28 | 110602 | 4 | 111 O-RING (NOTE 1) |
| 29 | 800419 | 1 | 12" MULTI-GRIP JAW SET (NOTE 2) |
| 30 | 800417 | 1 | 13" MULTI-GRIP JAW SET (NOTE 2) |
| 31 | 120181 | 1 | 127 S/N PLATE |
| 32 | 130381 | 4 | RIVET |
| 33 | 120761 | 2 | POINTED SET SCREW |

NOTE 1: Included in 127 Seal Kit 810629 Item 26

NOTE 2: Not part of Final Assembly



**MODEL 44-50
VIBRATORY
DRIVER/EXTRACTOR**

PARTS LIST

127 CLAMP 13" MULTI-GRIP JAW SET

800417

127 CLAMP 12" MULTI-GRIP JAW SET

800419

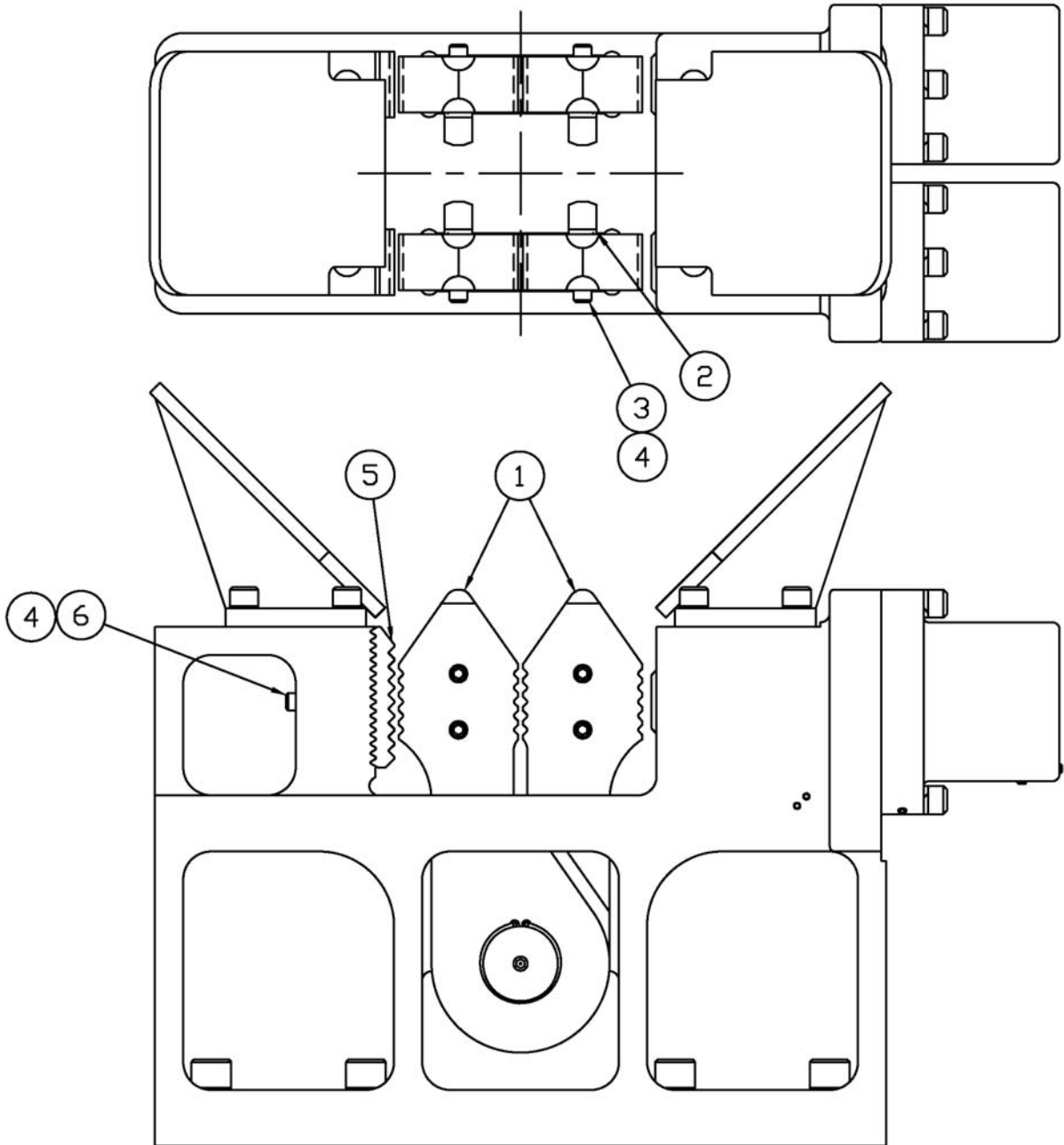



**MODEL 44-50
VIBRATORY
DRIVER/EXTRACTOR**

PARTS LIST

127 CLAMP 13" MULTI-GRIP JAW SET

800417

| <u>Item</u> | <u>Part Number</u> | <u>Qty.</u> | <u>Description</u> |
|-------------|------------------------|-------------|-------------------------|
| 1 | 120681 | 4 | MULTIGRIP JAW |
| 2 | 120205 | 4 | PZ 27 GUIDE |
| 3 | 100773 | 8 | .625-11 X 4.5 LG SHCS |
| 4 | 100007 | 10 | .625 LOCK WASHER MEDIUM |
| 5 | 120673 | 2 | JAW |
| 6 | 130849 | 2 | .625-11 X 5.00 SHCS |

127 CLAMP 12" MULTI-GRIP JAW SET

800419

| <u>Item</u> | <u>Part Number</u> | <u>Qty.</u> | <u>Description</u> |
|-------------|------------------------|-------------|-------------------------|
| 1.0 | 120679 | 4.0 | MULTI-GRIP JAW |
| 2.0 | 120205 | 4.0 | PZ 27 GUIDE |
| 3.0 | 100773 | 8.0 | .625-11 X 4.5 LG SHCS |
| 4.0 | 100007 | 10.0 | .625 LOCK WASHER MEDIUM |
| 5.0 | 120675 | 2.0 | JAW |
| 6.0 | 130849 | 2.0 | .625-11 X 5.00 SHCS |



MODEL 44-50
VIBRATORY
DRIVER/EXTRACTOR

PARTS LIST

10' CLAMP EXTENSION

800423

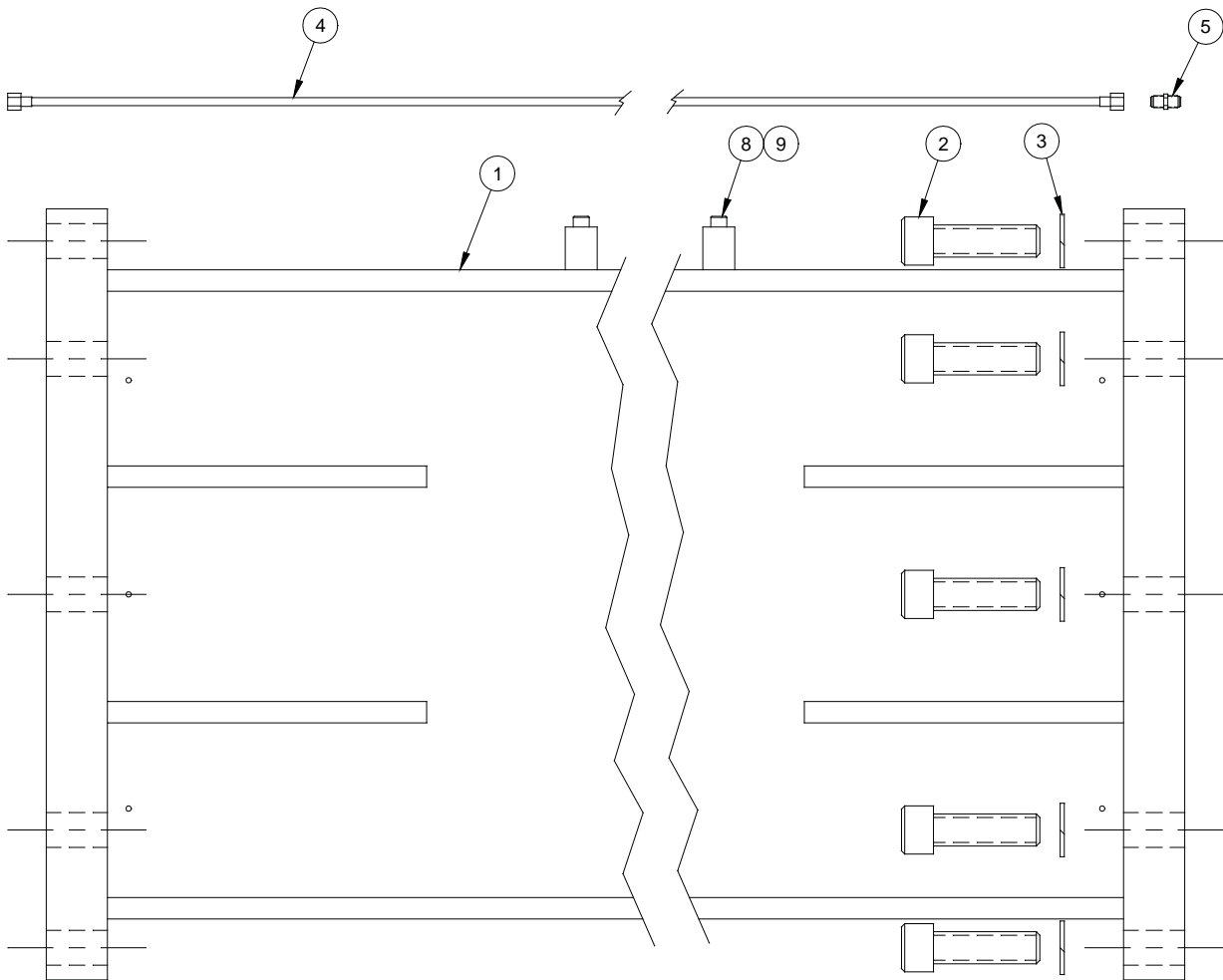



MODEL 44-50
VIBRATORY
DRIVER/EXTRACTOR

PARTS LIST

10' CLAMP EXTENSION

800423

| <u>Item</u> | <u>Part Number</u> | <u>Qty.</u> | <u>Description</u> |
|-------------|------------------------|-------------|-----------------------------|
| 1 | 810655 | 1 | 10 ft EXTENSION |
| 2 | 100193 | 10 | 1.5-6 X 5.0 LG SHCS |
| 3 | 100195 | 10 | 1.5 LOCK WASHER EXTRA HEAVY |
| 4 | 120193 | 2 | HOSE038R02J006J006L132OS |
| 5 | 120081 | 2 | FITT2S-06M06M000-000H001 |
| 6 | 100299 | 1 | PRIMER/GAL |
| 7 | 110156 | 1 | APE / J&M YELLOW PAINT/GAL |



MODEL 44-50
VIBRATORY
DRIVER/EXTRACTOR

PARTS LIST

90 DEGREE CLAMP ADAPTER

800049

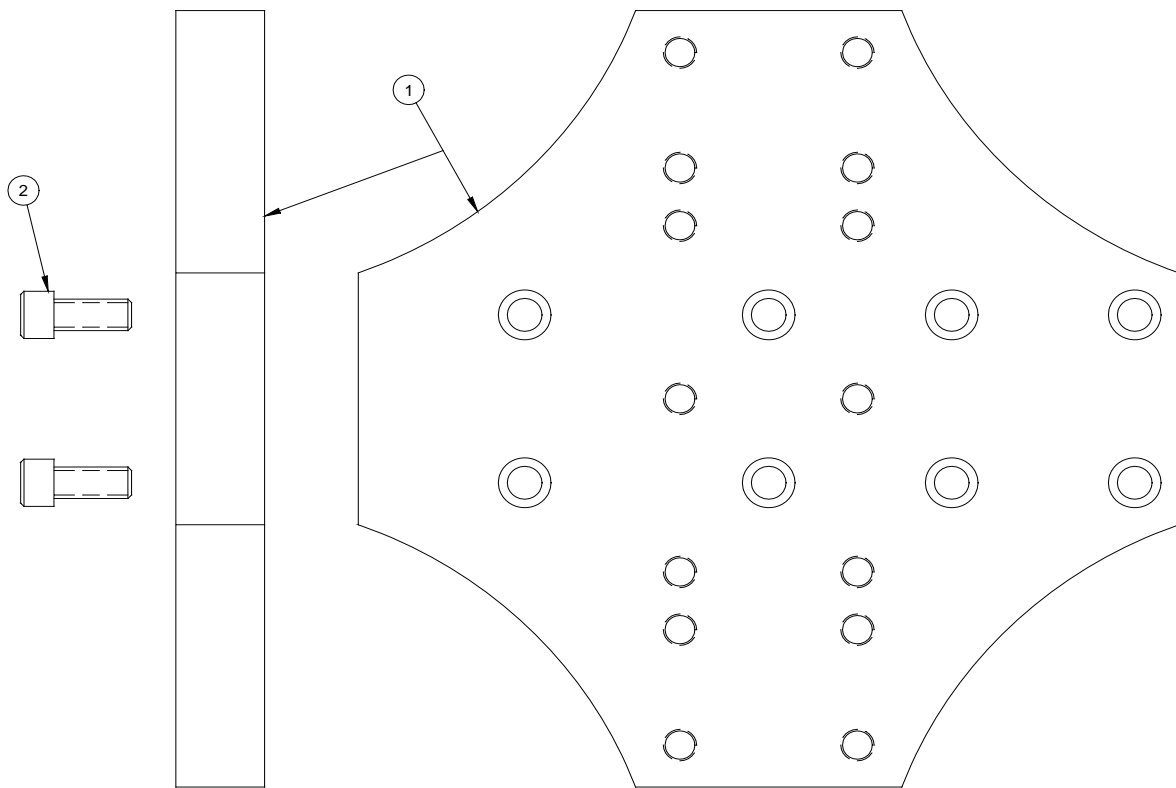



MODEL 44-50
VIBRATORY
DRIVER/EXTRACTOR

PARTS LIST

90 DEGREE CLAMP ADAPTER

800049

| <u>Item</u> | <u>Part Number</u> | <u>Qty.</u> | <u>Description</u> |
|-------------|------------------------|-------------|----------------------------|
| 1 | 120083 | 1 | 90 DEGREE CLAMP ADAPTER |
| 2 | 120077 | 8 | 1.5-6 x 3.5 LG SHCS |
| 3 | 130219 | 8 | 1.50 LOCK WASHER HI-COLLAR |



**MODEL 44-50
VIBRATORY
DRIVER/EXTRACTOR**

PARTS LIST

CAISSON BEAM - 7' (OPTIONAL)

800477

CAISSON BEAM - 11' (OPTIONAL)

800479

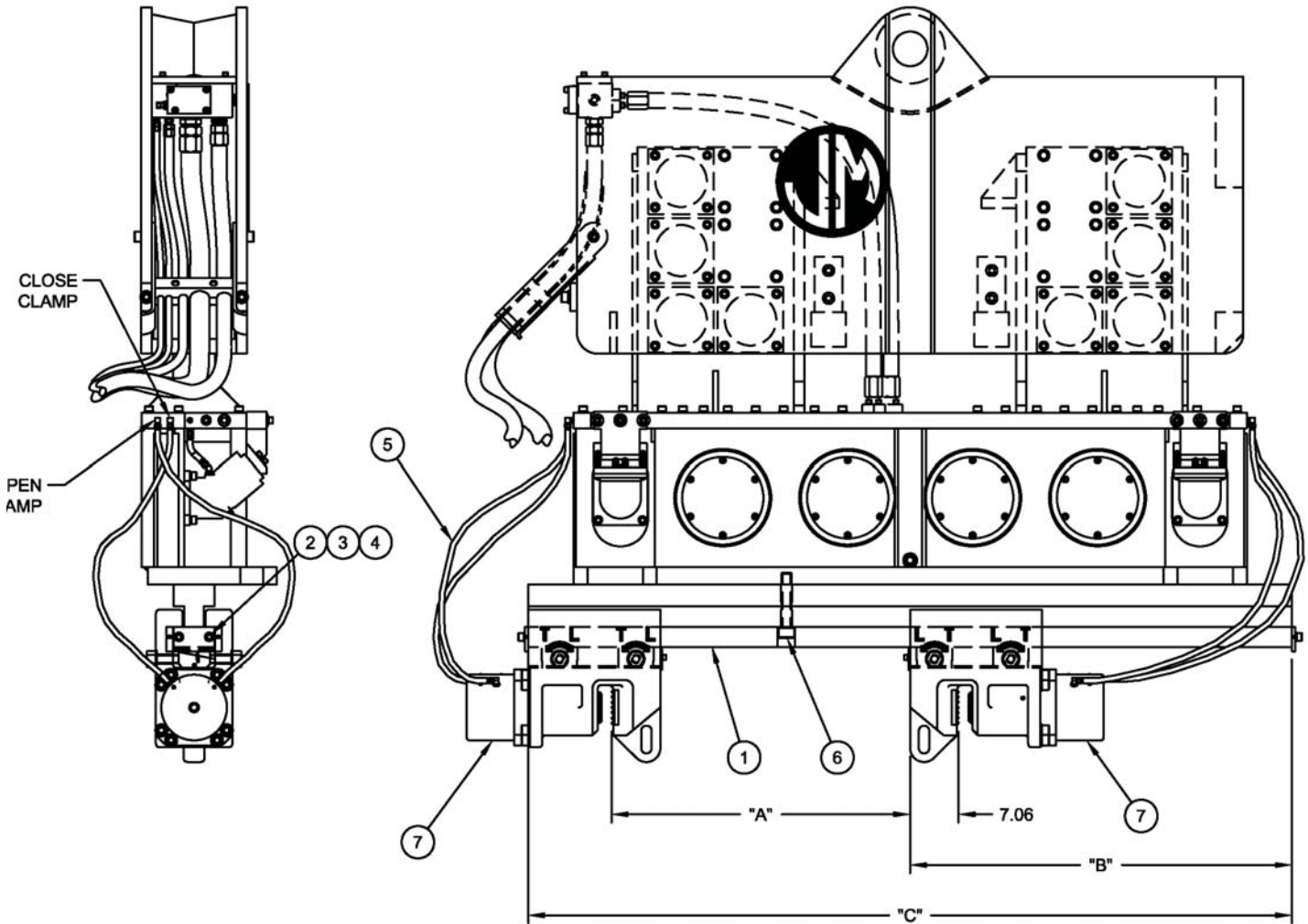

7' Caisson Beam (800477) - Shown
11' Caisson Beam (800479) - Similar

| | A | B | C |
|----------|-------|-------|--------|
| 7' Beam | 42.00 | 55.00 | 110.00 |
| 11' Beam | 68.00 | 75.00 | 150.00 |



MODEL 44-50
VIBRATORY
DRIVER/EXTRACTOR

PARTS LIST

CAISSON BEAM - 7'

800477

| <u>Item</u> | <u>Part Number</u> | <u>Qty.</u> | <u>Description</u> |
|-------------|------------------------|-------------|--------------------------|
| 1 | 120001 | 1 | CAISSON BEAM |
| 2 | 120011 | 2 | CLAMP STOP |
| 3 | 400069 | 4 | .75-10 x 2.0 LG SHCS |
| 4 | 100069 | 4 | .75 LOCK WASHER MEDIUM |
| 5 | 100228 | 4 | HOSE038R02J006J006L0610C |
| 6 | 120007 | 15 | 1.5-6 X 8.0 LG SHCS |
| 7 | 800047 | 2 | 80 CLAMP ASM (NOTE) |

CAISSON BEAM - 11'

800479

| <u>Item</u> | <u>Part Number</u> | <u>Qty.</u> | <u>Description</u> |
|-------------|------------------------|-------------|----------------------------|
| 1 | 810251 | 1 | 11 FT CAISSON BEAM |
| 2 | 120011 | 2 | CLAMP STOP |
| 3 | 400069 | 4 | .75-10 x 2.0 LG SHCS |
| 4 | 100069 | 4 | .75 LOCK WASHER MEDIUM |
| 5 | 120009 | 4 | HOSE038R02J006J006L0960S |
| 6 | 100193 | 14 | 1.5-6 X 5.0 LG SHCS |
| 7 | 800047 | 2 | 80 CLAMP ASM (NOTE) |
| 8 | 130219 | 14 | 1.50 LOCK WASHER HI-COLLAR |

Note: Not part of caisson beam assembly.



MODEL 44-50
VIBRATORY
DRIVER/EXTRACTOR

PARTS LIST

80 CLAMP WITH WEDGE LOCKS

800047

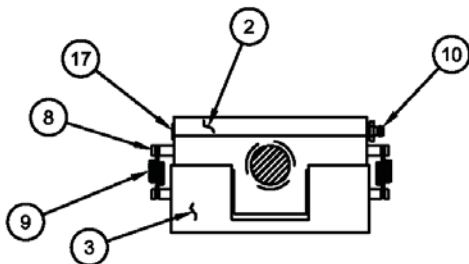
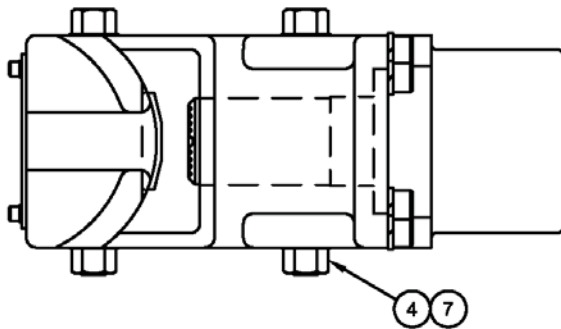
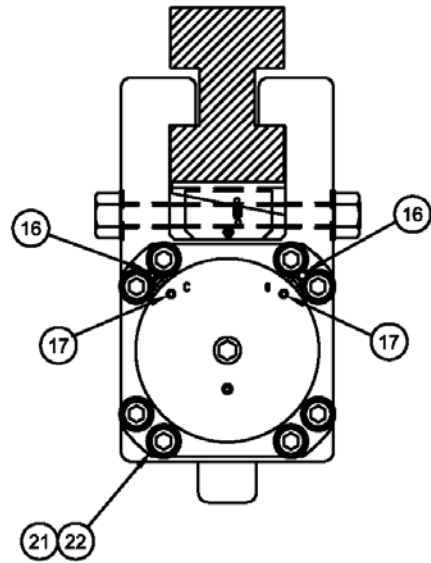
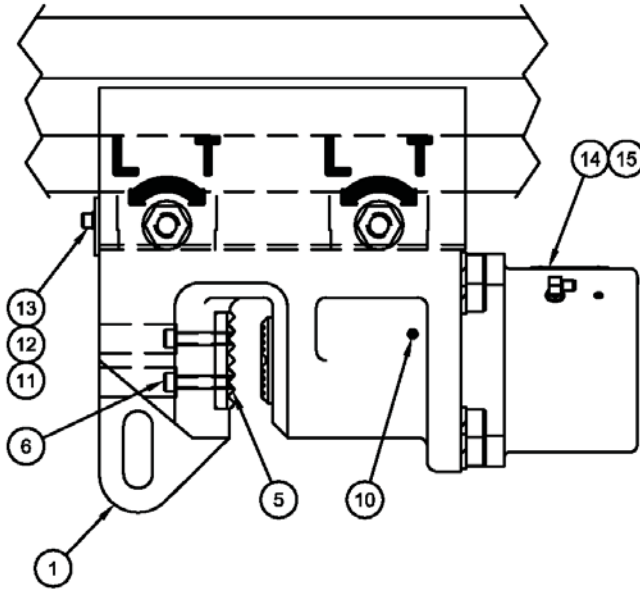

WEDGE LOCK DETAIL

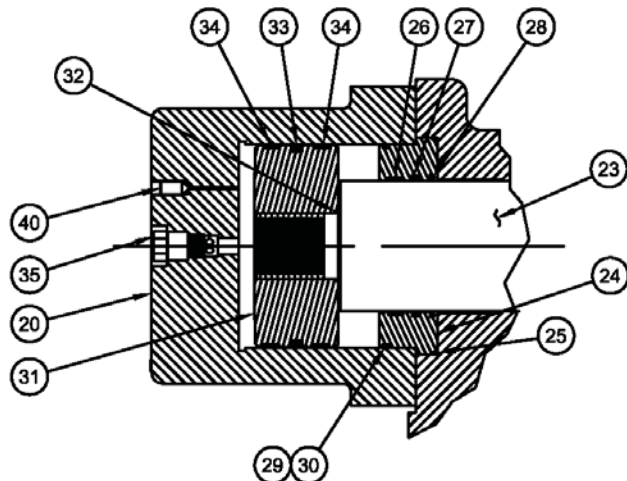

CYLINDER DETAIL



MODEL 44-50
VIBRATORY
DRIVER/EXTRACTOR

PARTS LIST

80 CLAMP WITH WEDGE LOCKS

800047

| Item | Part Number | Qty. | Description |
|------|-------------|------|-----------------------------------|
| 1 | 810061 | 1 | 80 CLAMP BODY |
| 2 | 120101 | 2 | WEDGE |
| 3 | 120103 | 2 | LOCK |
| 4 | 810109 | 2 | SCREW ASM (80) |
| 5 | 120107 | 1 | JAW |
| 6 | 400157 | 2 | .625-11 x 2.75 LG SHCS |
| 7 | 120111 | 4 | 1.25 H. S. FLAT WASHER |
| 8 | 120113 | 8 | .25 x 1 TYPE G DRIVE PIN |
| 9 | 120115 | 4 | SPRING |
| 10 | 100229 | 3 | GREASE FITTING |
| 11 | 120119 | 1 | WEDGE GUARD |
| 12 | 100119 | 2 | .5-13 X 1.25 LG SHCS LOC WEL |
| 13 | 100121 | 4 | .50 LOCK WASHER MEDIUM |
| 14 | 120159 | 1 | 80 S/N PLATE |
| 15 | 130381 | 4 | RIVET |
| 16 | 130057 | 2 | FITT2L-06M06R000-000H001 |
| 17 | 100646 | 6 | FITT2P-02P000000-000S007 |
| 18 | 100299 | 1 | PRIMER/GAL |
| 19 | 110156 | 1 | APE / J&M YELLOW PAINT/GAL |
| 20 | 120621 | 1 | CYLINDER (80) |
| 21 | 100212 | 8 | 1.0-8 X 4.00 LG SHCS LOC WEL |
| 22 | 100209 | 8 | 1.00 LOCK WASHER MEDIUM |
| 23 | 120631 | 1 | CYLINDER ROD (80) |
| 24 | 120623 | 1 | ROD END CAP (80) |
| 25 | 120100 | 1 | 2-263 O-RING 90 DURO (NOTE) |
| 26 | 120627 | 1 | ROD BEARING (80) (NOTE) |
| 27 | 120625 | 1 | ROD SEAL (80) (NOTE) |
| 28 | 120345 | 1 | ROD WIPER (NOTE) |
| 29 | 120347 | 1 | 2-261 O-RING 90 DURO (NOTE) |
| 30 | 120349 | 1 | 261 BACK-UP RING PC TEFLON (NOTE) |
| 31 | 120313 | 1 | PISTON - (80; 216; WPH) |
| 32 | 120281 | 1 | 2-140 O-RING (NOTE) |
| 33 | 120357 | 1 | PISTON SEAL (NOTE) |
| 34 | 120355 | 2 | PISTON BEARING (NOTE) |
| 35 | 120629 | 1 | HOLDING VALVE CARTRIDGE |
| 36 | 810611 | 1 | 80 SEAL KIT |
| 37 | 120751 | 1 | CHAIN ANCHOR |
| 38 | 100513 | 2 | .5-13 X 1.5 LG SHCS |
| 39 | 400992 | 1 | FITT2P-06R000000-000S001 |
| 40 | 120761 | 1 | POINTED SET SCREW |

Note: Included in Model 80 Seal Kit 810611 Item 36



MODEL 44-50
VIBRATORY
DRIVER/EXTRACTOR

PARTS LIST

80 CLAMP WITH LOCK BODY

800413

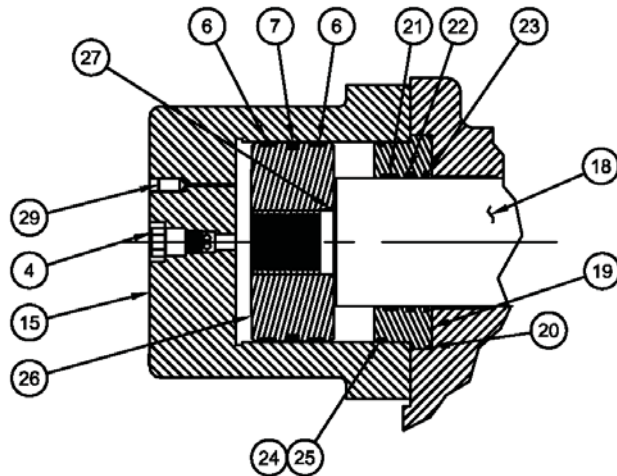
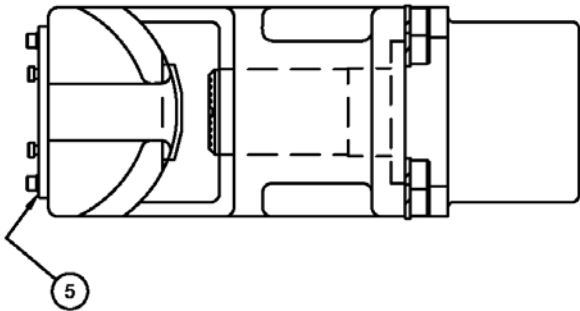
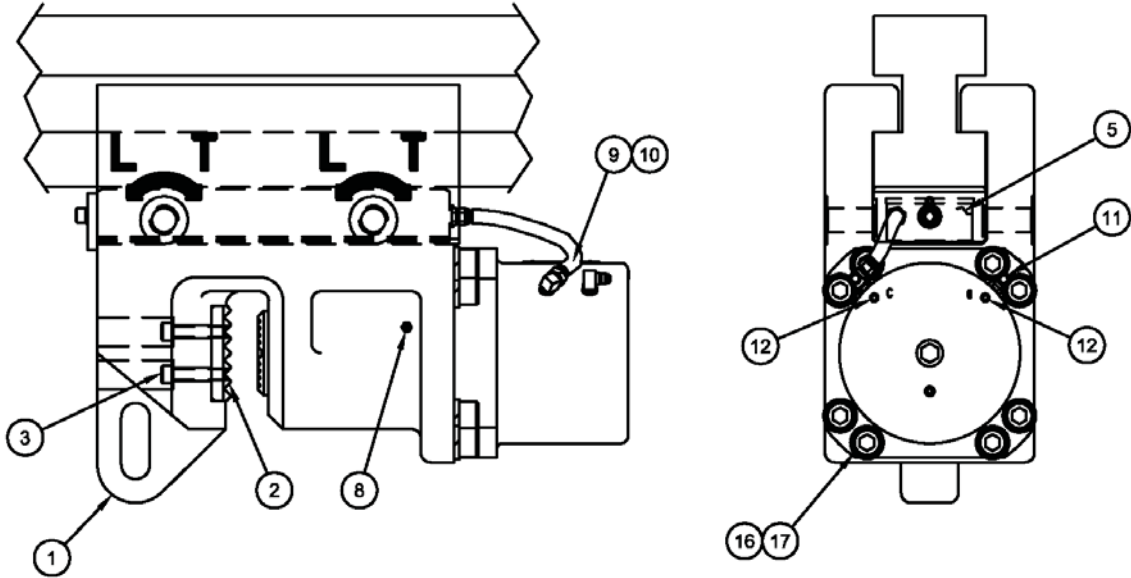

CYLINDER DETAIL



MODEL 44-50
VIBRATORY
DRIVER/EXTRACTOR

PARTS LIST

80 CLAMP WITH LOCK BODY

800413

| Item | Part Number | Qty. | Description |
|------|-------------|------|-----------------------------------|
| 1 | 810061 | 1 | 80 CLAMP BODY |
| 2 | 120107 | 1 | JAW |
| 3 | 400157 | 2 | .625-11 x 2.75 LG SHCS |
| 4 | 120629 | 1 | HOLDING VALVE CARTRIDGE |
| 5 | 800399 | 1 | LOCK BODY ASM. |
| 6 | 120355 | 2 | PISTON BEARING (NOTE) |
| 7 | 120357 | 1 | PISTON SEAL (NOTE) |
| 8 | 100229 | 1 | GREASE FITTING |
| 9 | 120159 | 1 | 80 S/N PLATE |
| 10 | 130381 | 4 | RIVET |
| 11 | 130057 | 2 | FITT2L-06M06R000-000H001 |
| 12 | 100646 | 4 | FITT2P-02P000000-000S007 |
| 13 | 100299 | 1 | PRIMER/GAL |
| 14 | 110156 | 1 | APE / J&M YELLOW PAINT/GAL |
| 15 | 120621 | 1 | CYLINDER (80) |
| 16 | 100212 | 8 | 1.0-8 X 4.00 LG SHCS LOC WEL |
| 17 | 100209 | 8 | 1.00 LOCK WASHER MEDIUM |
| 18 | 120631 | 1 | CYLINDER ROD (80) |
| 19 | 120623 | 1 | ROD END CAP (80) |
| 20 | 120100 | 1 | 2-263 O-RING 90 DURO (NOTE) |
| 21 | 120627 | 1 | ROD BEARING (80) (NOTE) |
| 22 | 120625 | 1 | ROD SEAL (80) (NOTE) |
| 23 | 120345 | 1 | ROD WIPER (NOTE) |
| 24 | 120347 | 1 | 2-261 O-RING 90 DURO (NOTE) |
| 25 | 120349 | 1 | 261 BACK-UP RING PC TEFLON (NOTE) |
| 26 | 120313 | 1 | PISTON - (80; 13; WPH) |
| 27 | 120281 | 1 | 2-140 O-RING (NOTE) |
| 28 | 810611 | 1 | 80 SEAL KIT |
| 29 | 120761 | 1 | POINTED SET SCREW |

Note: Included in Model 80 Seal Kit 810611 Item 28



MODEL 44-50
VIBRATORY
DRIVER/EXTRACTOR

PARTS LIST

LOCK BODY

800399

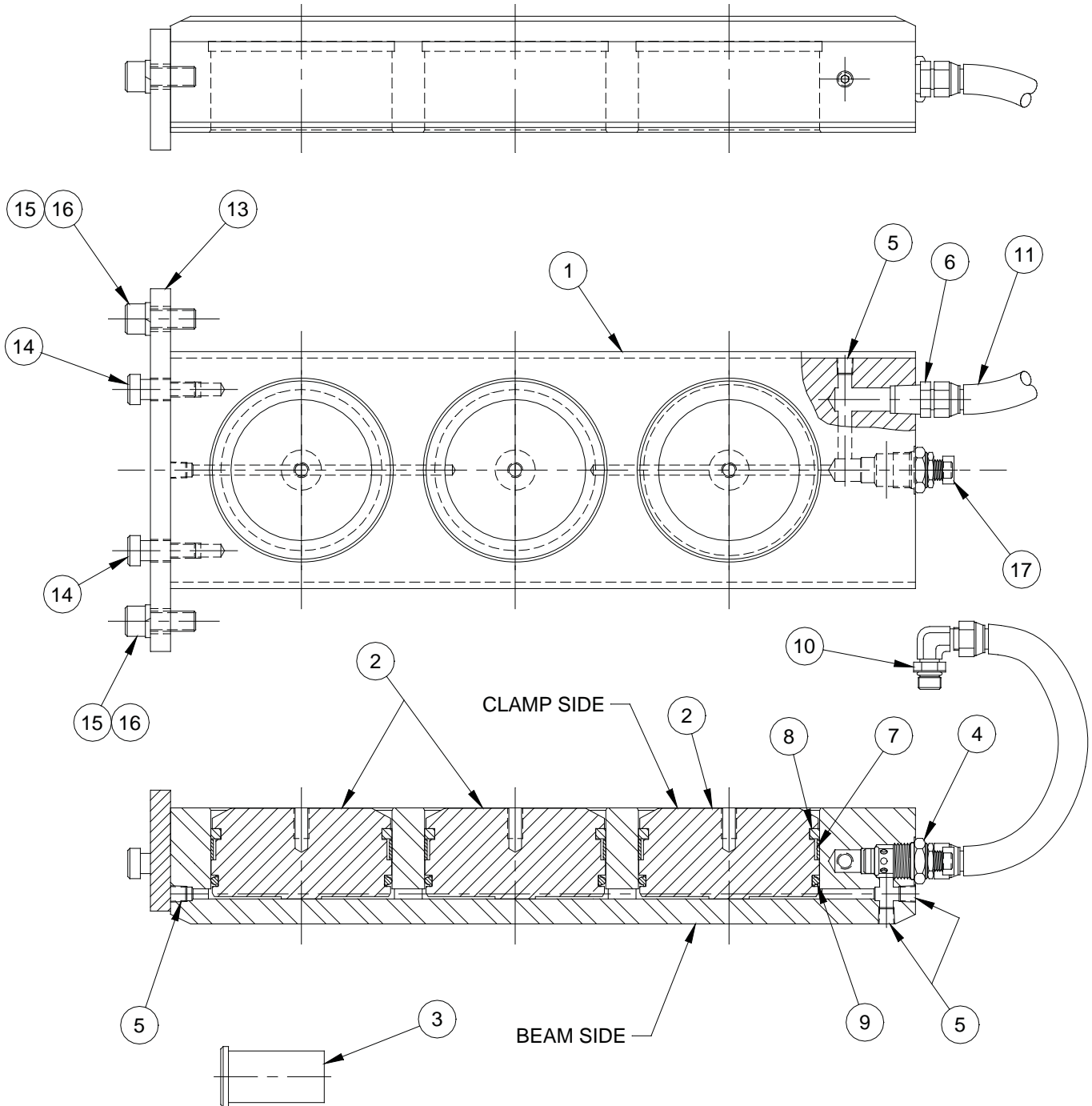



MODEL 44-50
VIBRATORY
DRIVER/EXTRACTOR

PARTS LIST

LOCK BODY

800399

| Item | Part Number | Qty. | Description |
|------|-------------|------|------------------------------|
| 1 | 120639 | 1 | LOCK BODY |
| 2 | 120641 | 3 | PISTON |
| 3 | 120643 | 4 | BUTTON |
| 4 | 120651 | 1 | LOCK BODY HOLDING VALVE |
| 5 | 100646 | 4 | FITT2P-02P000000-000S007 |
| 6 | 400203 | 1 | FITT2S-06M06P000-000H001 |
| 7 | 120645 | 3 | PISTON BEARING |
| 8 | 120649 | 3 | PISTON WIPER |
| 9 | 120647 | 3 | PISTON SEAL |
| 10 | 130057 | 1 | FITT2L-06M06R000-000H001 |
| 11 | 120657 | 1 | HOSE038RO2J006J006L0090C |
| 13 | 120653 | 1 | L.B. RETAINER PLATE |
| 14 | 140143 | 2 | .5 X .75 LG SHCS SHOULDER |
| 15 | 100119 | 2 | .5-13 X 1.25 LG SHCS LOC WEL |
| 16 | 100121 | 2 | .50 LOCK WASHER MEDIUM |

810859 80B LOCK BODY SEAL KIT

Operation of Lock Body:

Position Calmps on Beam to suit your Piling. Close Holding Valve Item 4 by turning CW, CLOSE Clamp to energize LOCK BODY. To reposition Clamp on Beam, Open Holding valve Item 4 by turning CCW, and OPEN Clamp to release LOCK BODY.



MODEL 44-50
VIBRATORY
DRIVER/EXTRACTOR

PARTS LIST

50' PENDANT EXTENSION CABLE

800059

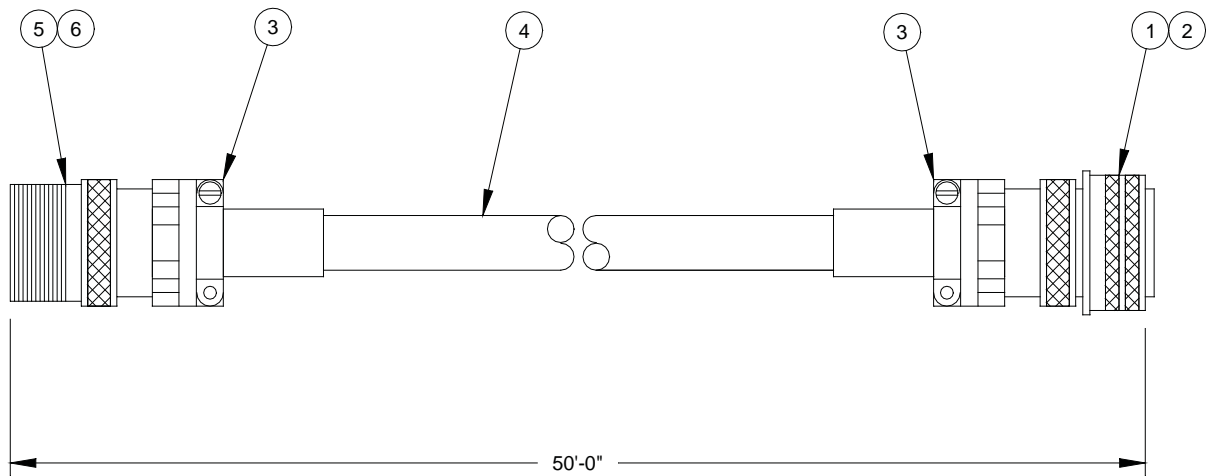



MODEL 44-50
VIBRATORY
DRIVER/EXTRACTOR

PARTS LIST

50' PENDANT EXTENSION CABLE

800059

| <u>Item</u> | <u>Part Number</u> | <u>Qty.</u> | <u>Description</u> |
|-------------|------------------------|-------------|--------------------------|
| 1 | 120169 | 1 | AMPHENOL CABLE JACK |
| 2 | 110763 | 1 | FEMALE AMPHENOL INSERT |
| 3 | 100375 | 2 | STRAIN RELIEF-AMPHENOL |
| 4 | 100560 | 50 | PENDANT CABLE/FT |
| 5 | 100395 | 1 | AMPHENOL PLUG |
| 6 | 110761 | 1 | MALE AMPHENOL INSERT-PLG |



MODEL 44-50
VIBRATORY
DRIVER/EXTRACTOR

PARTS LIST

BIAS WEIGHT ASSEMBLY

800429

2,700 LBS / PAIR 1,350 LBS EACH

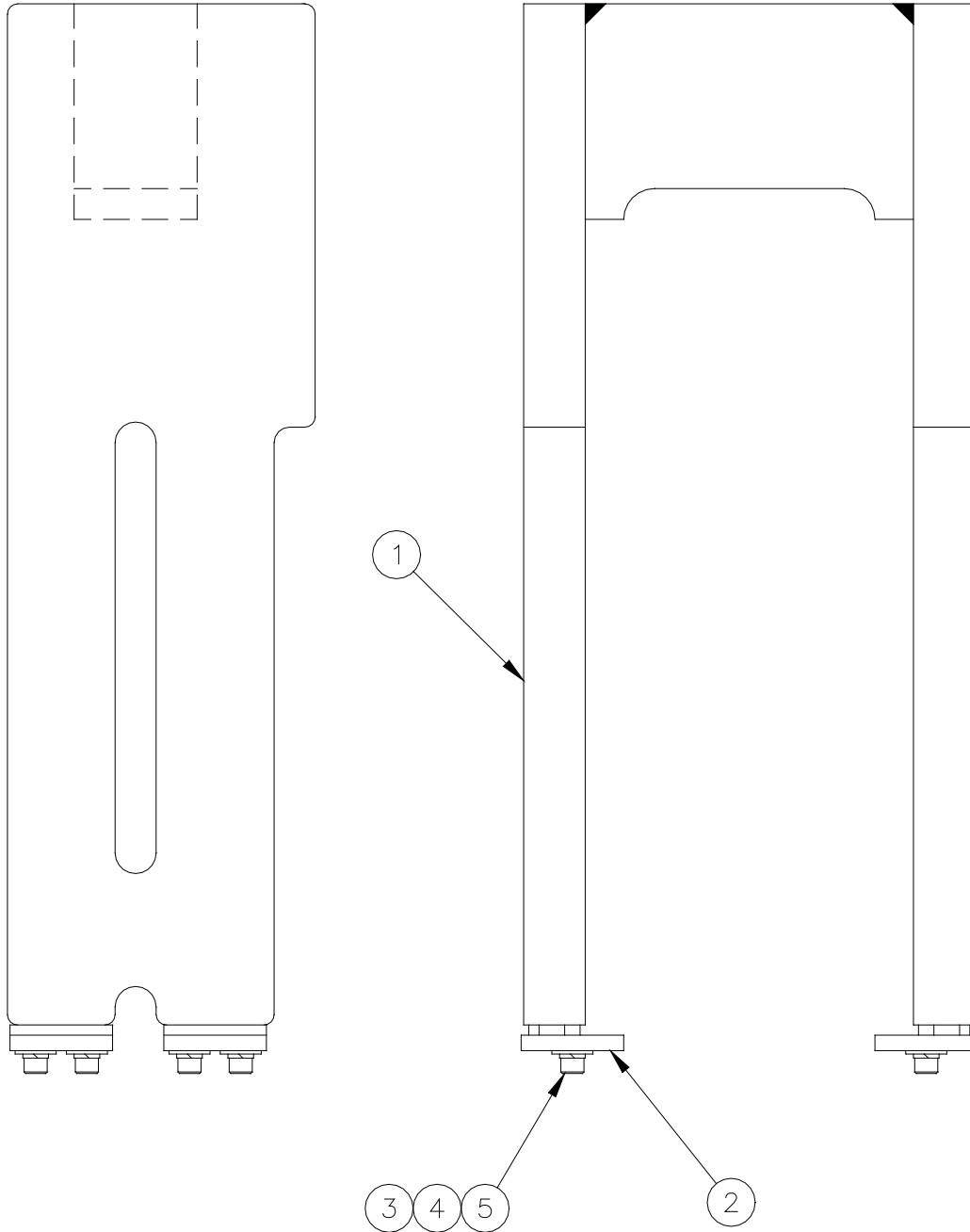



MODEL 44-50
VIBRATORY
DRIVER/EXTRACTOR

PARTS LIST

BIAS WEIGHT ASSEMBLY

800429

| <u>Item</u> | <u>Part Number</u> | <u>Qty.</u> | <u>Description</u> |
|-------------|------------------------|-------------|------------------------|
| 1 | 110338 | 2 | BIAS WEIGHT |
| 2 | 110326 | 8 | CLIP |
| 3 | 400545 | 16 | .75-10 UNC X 3 LG SHCS |
| 4 | 100069 | 16 | .75 LOCK WASHER MEDIUM |
| 5 | 100589 | 16 | .75 FLAT WASHER |



MODEL 44-50
VIBRATORY
DRIVER/EXTRACTOR

PARTS LIST

VIII. ORDERING PARTS

E. MISCELLANEOUS ACCESSORIES

1. Tools

| <u>Part Number</u> | <u>Qty.</u> | <u>Description</u> |
|--------------------|-------------|---|
| 100651 | 1 | 24-Volt Test Light |
| 810045 | 1 | Set of Allen Wrenches - Includes All Wrenches Shown Below: |
| 100655 | | (1) 1/16" Allen Wrench - Long Arm |
| 100691 | | (1) 5/64" Allen Wrench - Long Arm |
| 100659 | | (1) 3/32" Allen Wrench - Long Arm |
| 100661 | | (1) 7/64" Allen Wrench - Long Arm |
| 100663 | | (1) 1/ 8" Allen Wrench - Long Arm |
| 100665 | | (1) 9/64" Allen Wrench - Long Arm |
| 100667 | | (1) 5/32" Allen Wrench - Long Arm |
| 100669 | | (1) 3/16" Allen Wrench - Long Arm |
| 100671 | | (1) 7/32" Allen Wrench - Long Arm |
| 100673 | | (1) 1/ 4" Allen Wrench - Long Arm |
| 100657 | | (1) 5/16" Allen Wrench - Long Arm |
| 100675 | | (1) 3/ 8" Allen Wrench - Long Arm |
| 100677 | | (1) 7/16" Allen Wrench - Long Arm |
| 100679 | | (1) 1/ 2" Allen Wrench - Long Arm |
| 100681 | | (1) 9/16" Allen Wrench - Long Arm |
| 100683 | | (1) 5/ 8" Allen Wrench - Long Arm |
| 100685 | | (1) 3/ 4" Allen Wrench - Long Arm |
| 100687 | | (1) 7/ 8" Allen Wrench - Short Arm |
| 100689 | | (1) 1" Allen Wrench - Short Arm |

2. Bulk

| <u>Part Number</u> | <u>Qty.</u> | <u>Description</u> |
|--------------------|-------------|--------------------------|
| 810013 | 5 GAL | Hydraulic Fluid |
| 810011 | 5 GAL | Vibration Case Lubricant |
| 100726 | 1 GAL | Coolant/Anti-Freeze |
| 100298 | 1 GAL | APE / J&M Yellow Paint |
| 100299 | 1 GAL | Primer |



MODEL 44-50
VIBRATORY
DRIVER/EXTRACTOR

PARTS LIST

VIII. ORDERING PARTS

E. MISCELLANEOUS ACCESSORIES (CONTINUED)

3. 44 Hose Group Kit - Internal

| Item | P/N | Qty. | Description | Page Ref. |
|------|--------|------|--------------------------|-----------|
| 15 | 140907 | 2 | HOSE150PT6F024F024L0835C | VIII-6 |
| 27 | 140905 | 2 | HOSE038R02J006J006L0835C | VIII-6 |
| 32 | 140903 | 1 | HOSE075PT4F012F012L0835C | VIII-6 |

4. 580 Hose Group Kit - Internal

| Item | P/N | Qty. | Description | Page Ref. |
|------|--------|------|--------------------------|-----------|
| 76 | 400215 | 1 | HOSE100R01P016P016L08400 | VIII-25 |
| 81 | 110130 | 1 | HOSE075R01J012J012L05999 | VIII-25 |
| 87 | 170874 | 1 | HOSE075R01J012J012L04150 | VIII-24 |
| 88 | 170932 | 1 | HOSE025R01J004J004L10700 | VIII-24 |
| 92 | 170932 | 1 | HOSE150R01J024F924L17200 | VIII-24 |
| 93 | 170938 | 1 | HOSE150R01J024J024L13450 | VIII-24 |
| 105 | 110680 | 1 | HOSE025R02J004J004L40000 | VIII-24 |
| 106 | 110474 | 1 | HOSE100PT4F016F920L04350 | VIII-24 |
| 107 | 110476 | 1 | HOSE100PT4F016F920L04100 | VIII-24 |
| 109 | 110478 | 1 | HOSE100PT4F016F920L04000 | VIII-24 |
| 127 | 110100 | 1 | HOSE100PT4F016F920L04250 | VIII-24 |
| 138 | 110122 | 1 | HOSE100R01P016J016L10100 | VIII-24 |
| 140 | 170920 | 1 | HOSE050PT4J008J008L08700 | VIII-24 |
| 143 | 170934 | 1 | HOSE075R01J012J012L05700 | VIII-25 |
| 145 | 170940 | 1 | HOSE150R01J024J024L04250 | VIII-24 |
| 146 | 110780 | 1 | HOSE150R01J024F924L04900 | VIII-25 |
| 147 | 110780 | 1 | HOSE150R01J024F924L04900 | VIII-25 |
| 149 | 170924 | 2 | HOSE250R0400000000L01600 | VIII-24 |
| 152 | 130207 | 2 | HOSE019R01J004J004L10000 | VIII-24 |
| 153 | 110120 | 1 | HOSE038R02J006J006L06900 | VIII-24 |
| 28 | 100719 | 1 | HOSE025R02J004J004L03000 | VIII-32 |
| 31 | 100149 | 1 | HOSE025R02J004J004L01900 | VIII-32 |



**MODEL 44-50
VIBRATORY
DRIVER/EXTRACTOR**

PARTS LIST

VIII. ORDERING PARTS

E. MISCELLANEOUS ACCESSORIES (CONTINUED)

5. 44-50 O-Ring Kit

| <u>P/N</u> | <u>Qty.</u> | <u>Description</u> |
|------------|-------------|-----------------------------|
| 100037 | 4 | 2-222 O-ring |
| 110119 | 8 | 2-225 O-ring |
| 100097 | 2 | 2-214 O-ring |
| 170811 | 250 | O-ring Cord 0.125 CS / Inch |
| 400053 | 8 | 2-273 O-ring |
| 110195 | 2 | 2-163 O-ring |
| 170833 | 2 | 2-161 O-ring |
| 140255 | 2 | 2-113 O-ring |

6. 580 O-Ring Kit

| <u>P/N</u> | <u>Qty.</u> | <u>Description</u> |
|------------|-------------|--------------------|
| 100037 | 4 | 2-222 O-ring |
| 110119 | 4 | 2-225 O-ring |
| 400379 | 2 | 2-232 O-ring |
| 120683 | 2 | 2-248 O-ring |
| 100091 | 4 | 2-219 O-ring |
| 110602 | 2 | 2-111 O-ring |
| 120891 | 15 | 2-015 O-ring |
| 170972 | 1 | 2-011 O-ring |

7. Quick Disconnect Rebuild Kit

850067

| <u>Qty.</u> | <u>Description</u> |
|-------------|---------------------------|
| 1 | Male Check Poppet Valve |
| 1 | Female Check Poppet Valve |
| 2 | Snap-Lock Ring |
| 1 | Snap-Ring Pliers |

8. Quick Disconnect Seal Kit

850185

| <u>P/N</u> | <u>Qty.</u> | <u>Description</u> |
|------------|-------------|--------------------|
| 110829 | 2 | 2-230 O-ring |
| 110980 | 2 | 230 Backup |
| 110230 | 2 | 2-216 O-ring |



MODEL 44-50
VIBRATORY
DRIVER/EXTRACTOR

PARTS LIST

VIII. ORDERING PARTS

E. MISCELLANEOUS ACCESSORIES (CONTINUED)

9. Cylinder Seal Kit

MODEL 126 CLAMP CYLINDER 810515 Refer to page VIII-36

| <u>P/N</u> | <u>Qty</u> | <u>Description</u> |
|------------|------------|----------------------|
| 120285 | 2 | Piston Bearing |
| 120283 | 2 | Piston Seal |
| 120555 | 1 | Rod Bearing |
| 120553 | 1 | Rod Seal |
| 120401 | 1 | 2-269-O-Ring 90 Duro |

MODEL 127 Z-PILE CLAMP 810629 Refer to page VIII-38

| <u>P/N</u> | <u>Qty</u> | <u>Description</u> |
|------------|------------|----------------------|
| 120239 | 2 | 2-132-O-Ring |
| 120243 | 4 | Piston Bearing |
| 120245 | 4 | Piston Seal |
| 120665 | 2 | Rod Bearing |
| 120667 | 2 | Rod Seal |
| 120347 | 2 | 2-261 O-Ring 90 Duro |
| 110602 | 4 | 2-111-O-Ring |

MODEL 80 CAISSON CLAMP 810611 Refer to page VIII-48

| <u>P/N</u> | <u>Qty</u> | <u>Description</u> |
|------------|------------|--------------------|
| 120100 | 1 | 2-263-O-Ring |
| 120627 | 1 | Rod Bearing |
| 120625 | 1 | Rod Seal |
| 120345 | 1 | Rod Wiper |
| 120347 | 1 | 2-261-O-Ring |
| 120349 | 1 | 261-Back-Up Ring |
| 120281 | 1 | 2-140-O-Ring |
| 120357 | 1 | Piston Seal |
| 120355 | 2 | Piston Bearing |



**MODEL 44-50
VIBRATORY
DRIVER/EXTRACTOR**

PARTS LIST

VIII. ORDERING PARTS

F. RECOMMENDED SPARE PARTS

VIBRATION SUPPRESSOR 800427 Refer to page VIII-6

| <u>Item</u> | <u>P/N</u> | <u>Qty.</u> | <u>Description</u> |
|-------------|------------|-------------|-------------------------------|
| 23 | 100796 | 2 or 4 1 | Elastomer 44-50 O-ring Kit |

VIBRATION CASE 810649 Refer to page VIII-10

| <u>Item</u> | <u>P/N</u> | <u>Qty.</u> | <u>Description</u> |
|-------------|------------|-------------|--------------------|
| 15 | 100185 | 1 | Sight Gage |
| — | 110142 | 2 | Motor Shaft Seal |
| 20 | 100662 | 2 | Filter |

TERMINAL BLOCK 810019 Refer to page VIII-12

| <u>Item</u> | <u>P/N</u> | <u>Qty.</u> | <u>Description</u> |
|-------------|------------|-------------|--------------------|
| 5 | 110214 | 1 | Relief Valve |

HOSE ASSEMBLIES-INTERCONNECTING 800053 Refer to page VIII-14

| <u>Item</u> | <u>P/N</u> | <u>Qty</u> | <u>Description</u> |
|-------------|------------|------------|--------------------------|
| 5 | 110141 | 2 | HOSE150PT6J024J024L60000 |
| 9 | 110970 | 2 | HOSE200R02J032J032L60000 |
| 13 | 140685 | 2 | HOSE075R02J012J012L62000 |
| 17 | 100247 | 4 | HOSE038R02J006J006L62000 |

POWER UNIT - INTERNAL (580) 800595 Refer to page VIII-24 & 25

| <u>Item</u> | <u>P/N</u> | <u>Qty</u> | <u>Description</u> |
|-------------|------------|------------|------------------------------|
| 9 | 170931 | 1 | Fuel Water Separator Element |
| 99 | 810117 | 4 | Hyd.Oil Filter |
| 155 | 170882 | 1 | Air Filter Inner Element |
| 156 | 170884 | 1 | Air Filter Outer Element |
| 166 | 170876 | 1 | Oil Filter Element |
| 168 | 170878 | 1 | Fuel Filter Element |



**MODEL 44-50
VIBRATORY
DRIVER/EXTRACTOR**

PARTS LIST

VIII. ORDERING PARTS

F. RECOMMENDED SPARE PARTS (CONTINUED)

MODEL 126 CLAMP 800327 Refer to page VIII-36

| <u>Item</u> | <u>P/N</u> | <u>Qty.</u> | <u>Description</u> |
|-------------|------------|-------------|--------------------------|
| 16 | 130057 | 2 | FITT2L-06M06R000-0000001 |
| 18 | 100193 | 8 | 1.5-6 UNC x 5.0 Lg. SHCS |
| 19 | 100195 | 8 | 1.5 Lockwasher |
| 22 | 130561 | 2 | HOSE038R02J006J006L0700C |
| 26 | 810515 | 1 | 126B Seal Kit |
| 27 | 810495 | 1 | Universal Movable Jaw |
| 28 | 110515 | 1 | Universal Fixed Jaw |
| 29 | 810497 | 1 | H-Beam Movable Jaw |
| 30 | 110541 | 1 | H-Beam Fixed Jaw |
| 31 | 810499 | 1 | DS-Movable Jaw |
| 32 | 110419 | 1 | DS-Fixed Jaw |
| 33 | 130449 | 1 | Spiral Roll Pin |
| 35 | 120629 | 1 | Holding Valve Cartridge |

MODEL 127 Z-PILE CLAMP 800041 Refer to page VIII-38

| <u>Item</u> | <u>P/N</u> | <u>Qty.</u> | <u>Description</u> |
|-------------|------------|-------------|-----------------------------|
| 9 | 100053 | 2 | FITT2S-06MO6R000-000H001 |
| 10 | 100193 | 8 | 1.5-6 X 5.0 LG SHCS |
| 11 | 100195 | 8 | 1.5 Lock Washer Extra Heavy |
| 17 | 130561 | 2 | HOSE038R02J006J006L0700C |
| 26 | 810629 | 2 | 127B Z Seal Kit |
| 28 | 110602 | 4 | 111 O-Ring |

MODEL 80B CAISSON CLAMP 800047 Refer to page VIII-48

| <u>P/N</u> | <u>Qty.</u> | <u>Description</u> |
|------------|-------------|---------------------------|
| 810109 | 1 | Screw Assembly |
| 120107 | 1 | Fixed Jaw |
| 400157 | 2 | .625-11UNC x 2.75 LG SHCS |
| 130057 | 2 | FITT2L-06M06R000-000H001 |
| 120629 | 1 | Holding Valve |
| 810611 | 1 | Seal Kit |



MODEL 44-50
VIBRATORY
DRIVER/EXTRACTOR

PARTS LIST



**MODEL 44-50
VIBRATORY
DRIVER/EXTRACTOR**

PARTS LIST

G. RECOMMENDED TIGHTENING TORQUE

| Nominal Screw Size | Nominal Socket Size | Tightening Torque Ft-Lbs. (Kg-M) | Nominal Screw Size | Nominal Socket Size | Tightening Torque Ft-Lbs. (Kg-M) |
|--------------------------|---------------------------|--|--------------------------|---------------------------|--|
| #10-24 | 5/32 | 6 Ft-Lbs. (.83 Kg-M) | #10-32 | 5/32 | 6 Ft-Lbs. (.83 Kg-M) |
| 1/4-20 | 3/16 | 13 Ft-Lbs. (1.8 Kg-M) | 1/4-28 | 3/16 | 15 Ft-Lbs. (2.1 Kg-M) |
| 5/16-18 | 1/4 | 27 Ft-Lbs. (3.7 Kg-M) | 5/16-24 | 1/4 | 30 Ft-Lbs. (4.2 Kg-M) |
| 3/8-16 | 5/16 | 48 Ft-Lbs. (6.6 Kg-M) | 3/8-24 | 5/16 | 55 Ft-Lbs. (7.6 Kg-M) |
| 7/16-14 | 3/8 | 77 Ft-Lbs. (10.6 Kg-M) | 7/16-20 | 3/8 | 86 Ft-Lbs. (11.9 Kg-M) |
| 1/2-13 | 3/8 | 119 Ft-Lbs. (16.4 Kg-M) | 1/2-20 | 3/8 | 133 Ft-Lbs. (18.4 Kg-M) |
| 5/8-11 | 1/2 | 234 Ft-Lbs. (32.3 Kg-M) | 5/8-18 | 1/2 | 267 Ft-Lbs. (36.9 Kg-M) |
| 3/4-10 | 5/8 | 417 Ft-Lbs. (57.6 Kg-M) | 3/4-16 | 5/8 | 467 Ft-Lbs. (64.5 Kg-M) |
| 7/8-9 | 3/4 | 676 Ft-Lbs. (93.4 Kg-M) | 7/8-14 | 3/4 | 742 Ft-Lbs. (102.5 Kg-M) |
| 1-8 | 3/4 | 1,009 Ft-Lbs. (139.4 Kg-M) | 1-12 | 3/4 | 1,126 Ft-Lbs. (155.6 Kg-M) |
| 1-1/4-7 | 7/8 | 1,600 Ft-Lbs. (221.1 Kg-M) | 1-1/4-12 | 7/8 | 1,800 Ft-Lbs. (248.8 Kg-M) |
| 1-1/2-6 | 1 | 2,800 Ft-Lbs. (387 Kg-M) | 1-1/2-12 | 1 | 3,000 Ft-Lbs. (414.6 Kg-M) |

NOTE: These values are for Socket head cap screws only. Button heads, Flat heads and Set screws have different values. Check the Allen Hand Book for correct torque specifications.



MODEL 44-50
VIBRATORY
DRIVER/EXTRACTOR

PARTS LIST